

A.L.P.S.® Total Foot System

Design Rationale & Surgical Technique

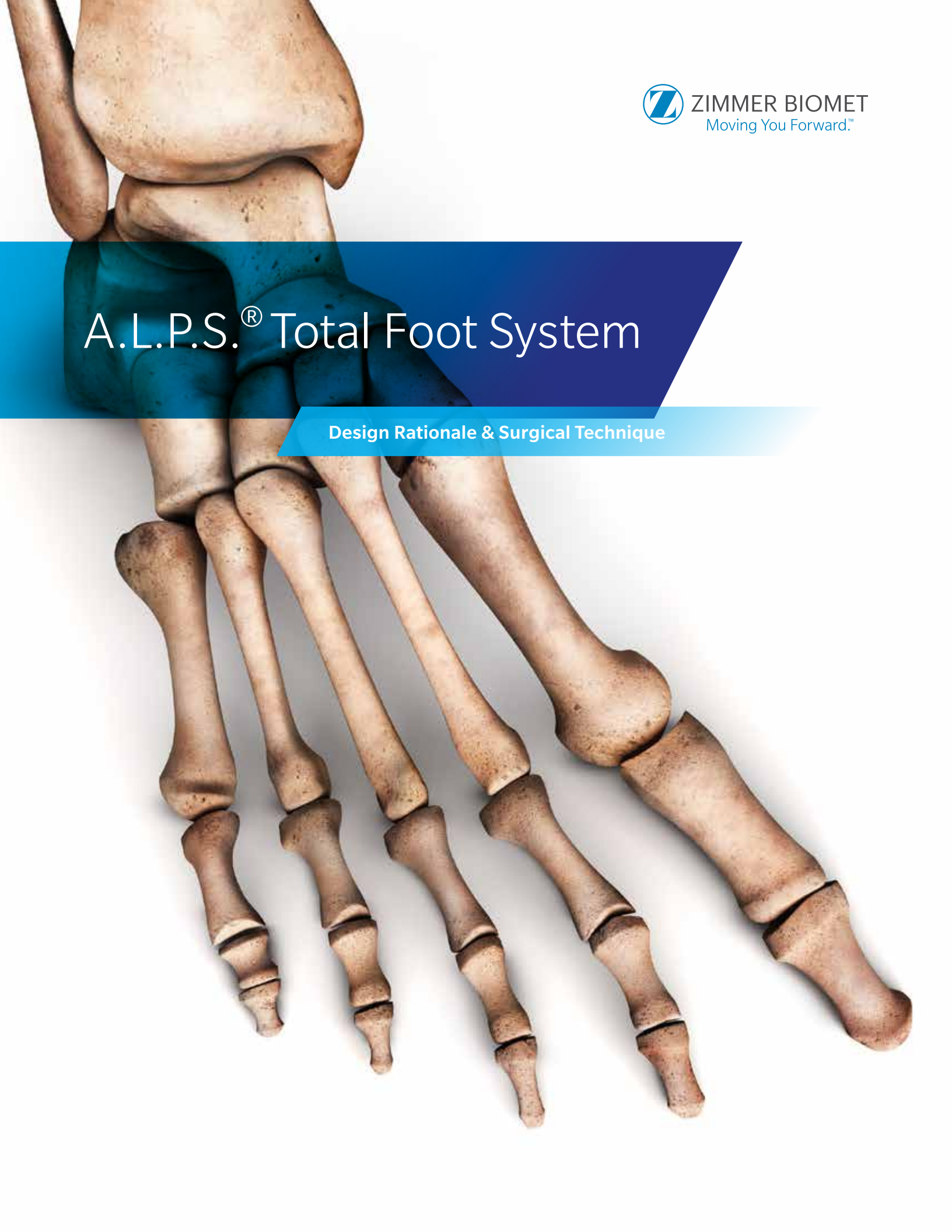

Table of Contents

Intended Use, Indications, and Contraindications	2
Introduction	3
1st Metatarsal Fusion Plate Technique.....	8
Lapidus Plate Technique	24
Single Joint Fusion Plate Technique	34
Dorsal Mid-Foot Fusion Plate Technique.....	48
Lateral Column Lengthening Plate Technique.....	58
Medial Column Fusion Plate Technique	66
Locking Calcaneal Plate Technique.....	76
Navicular Fracture Plate Technique	86
Talar Neck Fracture Plate Technique.....	93
Compression Wire Technique	102
2.5 Screw Options and Insertion Techniques	106
Small Frag Screw Options and Insertion Techniques.....	114
Ordering Information.....	127

Indications and Contraindications

Intended Use

These devices are intended for osteosynthesis.

Indications*

The A.L.P.S. Total Foot Plating System intended for use in stabilization and fixation of fractures, revision procedures, fusions, reconstructions (osteotomy) and non-unions of the bones of the hand, foot, wrist, ankle, finger, toe, humerus, olecranon, clavicle, scapula and pelvis, particularly in osteopenic bone. The system can be used in both adult and pediatric patients (adolescents [>12 - 21 years of age]), where the implant would not cross open epiphyseal plates in skeletally immature patients.

*In the European Economic Area (EEA), the A.L.P.S. Total Foot Plating System is indicated for temporary stabilization and fixation of foot fractures, osteotomies and arthrodesis.

Contraindications

1. Cases where there is an active infection.
2. Conditions which tend to retard healing such as, blood supply limitations, previous infections, etc.
3. Insufficient quantity or quality of bone to permit stabilization of the fracture.
4. Conditions that restrict the patient's ability or willingness to follow postoperative instructions during the healing process.
5. Foreign body sensitivity – where material sensitivity is suspected, appropriate tests should be conducted and sensitivity ruled out prior to implantations.
6. Cases where the implant(s) would cross open epiphyseal plates in skeletally immature patients.
7. Cases with malignant primary or metastatic tumors which preclude adequate bone support or screw fixations, unless supplemental fixation or stabilization methods are utilized.

Introduction

Low Profile, Anatomically Contoured Foot Plates

The A.L.P.S. Foot System offers a comprehensive set of plating options anatomically contoured to address — osteotomies, fusions and fractures in the forefoot, midfoot and hindfoot. The attention to anatomic detail is further enhanced by deliberate regions of flexibility to accommodate individual anatomic variation without compromising strength. The A.L.P.S. Foot System also offers a wide array of both locking and non-locking screw options and incorporates industry leading F.A.S.T. Guide technology. The result is a comprehensive yet flexible system for operating room efficiency and ease of use.



The A.L.P.S. Total Foot System is a comprehensive set of anatomically contoured implants to address a wide array of fusions and fractures in the forefoot, midfoot and hindfoot. The anatomic design of the plates are meant to closely match the natural anatomy. However, in-situ contouring is available for fine adjustment and patient specific customization.

- Low profile plate design to help minimize discomfort and soft tissue irritation.
- Engineered from TiMAX for strength, biocompatibility and enhanced imaging capabilities over stainless steel.²
- A smooth implant surface for minimized soft tissue irritation.
- Contoured plates mimic the anatomy of the foot.
- Adapters available for fixed angle K-wire placement for provisional fixation.

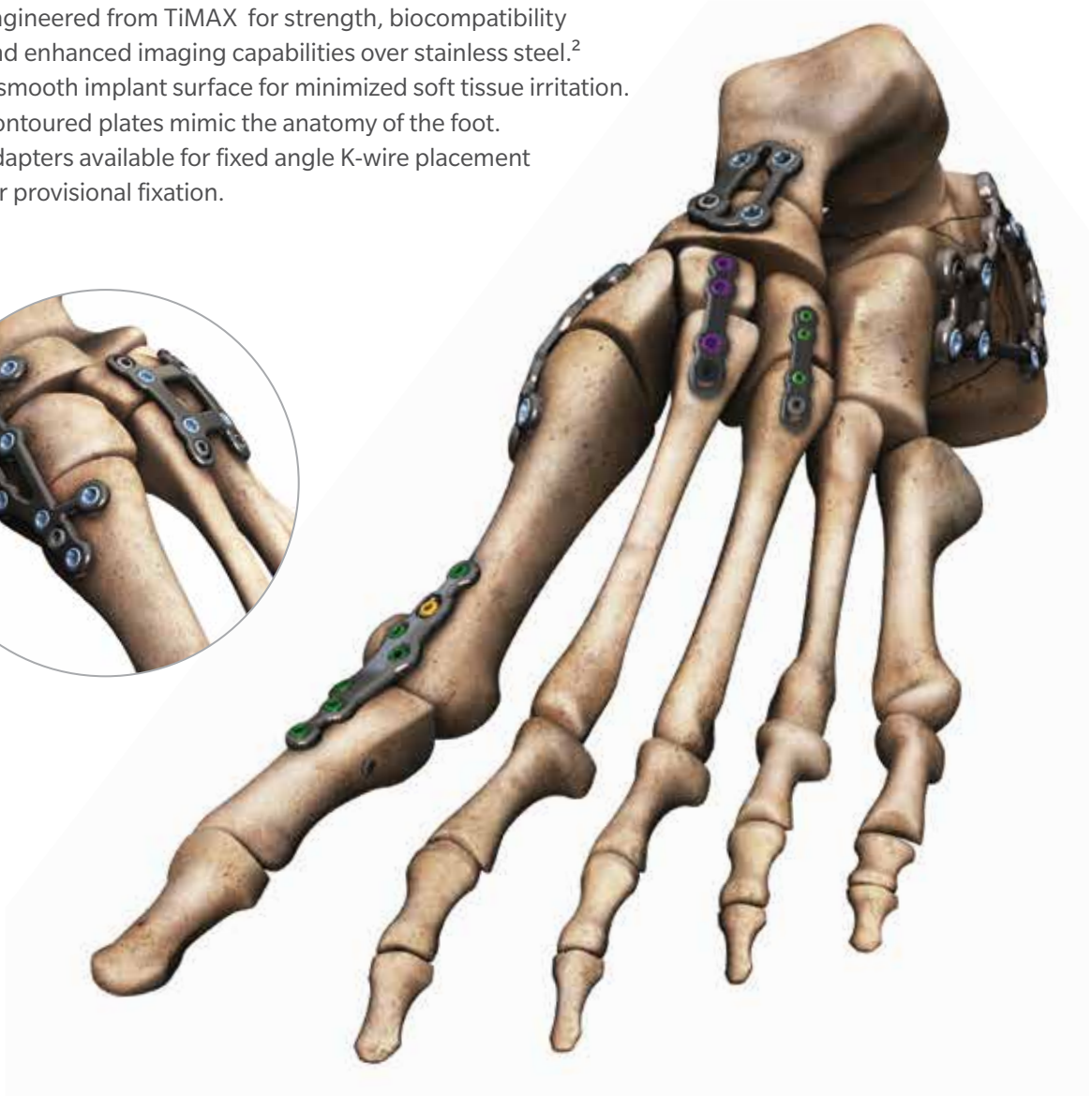

Fast, Accurate Surgeries F.A.S.T. Guide Inserts & F.A.S.T. Tabs Technologies

The A.L.P.S. Total Foot System comes pre-loaded with Fixed Angle Screw Targeting Guides—F.A.S.T. Guides—that direct the trajectory of the drill right through the plate. Additionally, F.A.S.T. Tabs technology allows for in-situ contouring for patient specific customization.

F.A.S.T. Guide Technology

Pre-loaded and disposable F.A.S.T. Guides facilitate accurate drilling and reduce intraoperative assembly for OR efficiency.

F.A.S.T. Tabs Technology

F.A.S.T. Tabs Technology enables in-situ contouring for true plate-to-bone conformity.

Provisional Fixation

Easy K-wire placement through provisional fixation holes.

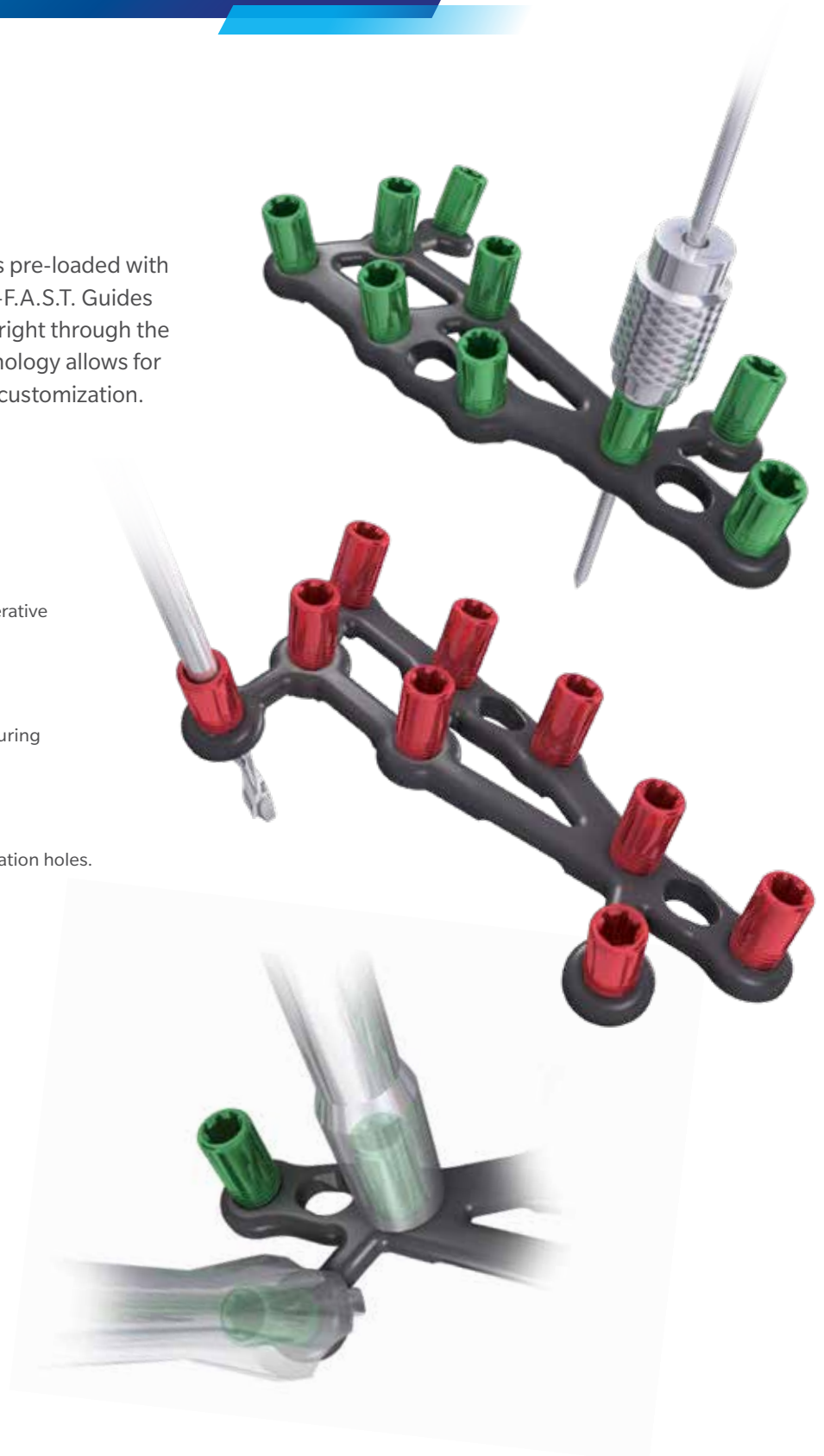

Locking, Non-Locking, and Multi-Directional Locking Screw options

Choose locking, non-locking, or multi-directional locking screws according to need and without compromising plate profile.

- Tapered, threaded screws lock into plate when tightened to establish a fixed angle construct for strong fixation or when bone quality is poor and optimal screw purchase is required.
- 2.5 mm Locking Multi-Directional Threaded Pegs (MDTP) allow up to a 20 degree cone, while the 3.5 mm Locking Multi-Directional Screws (MDS) allow a 25 or 30 degree cone depending on plate. These Cobalt Chrome screws lock into plate by creating their own thread limiting the risk of cold welding.
- Low profile non-locking screws provide the same profile as locking screws.
- Unidirectional compression holes allow for axial compression.





These are images of models with bones shown with plates in place and not real patients. They are provided to show positioning and not intended to suggest immediate weight bearing.

1st Metatarsal Fusion Plate Technique

The A.L.P.S. 1st Metatarsophalangeal (MTP) Joint Fusion plates are made of titanium alloy (Ti6Al4V) with a proprietary TiMAX treatment for increased fatigue strength compared to the standard alloy¹. The low-profile anatomic design and highly contoured surface minimizes potential soft tissue irritation. The 1st MTP Plates are available in Small (2.5 mm) and Large (3.5 mm) sizes with both right and left options and a predetermined dorsiflexion and valgus angle for excellent anatomic alignment. Offset fixation screws provide a convenient corridor for additional interfragmentary screw fixation; if desired, and have convergent trajectories for plate stability. Proprietary F.A.S.T. Guide technology provides a number of unique features to promote operating room efficiency and facilitate implant selection. The system offers multiple screw options defined by plate selection, including 2.5, 2.7, 3.5 and 4.0 mm Cortical Locking, 2.5 and 3.5 mm Cortical Non-Locking, and 2.5 and 3.5 mm Multi-Directional Locking Screws, all designed to maintain a low profile.

Cup and Cone Reamers are now available in the A.L.P.S. Total Foot System and may be used to prepare the first (and lesser) metatarsophalangeal joints for arthrodesis.

1st Metatarsal Fusion Plate – 2.5 mm

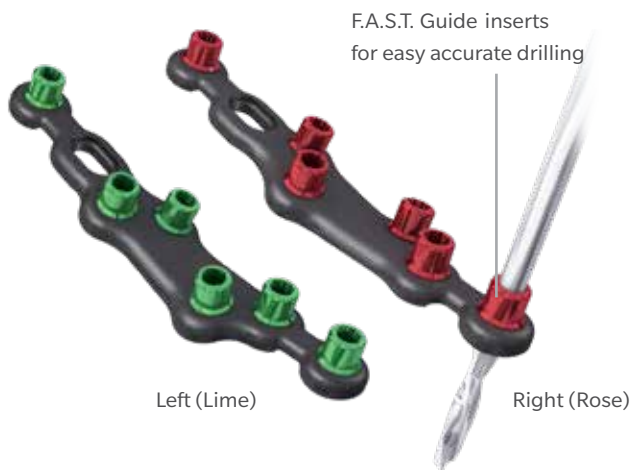
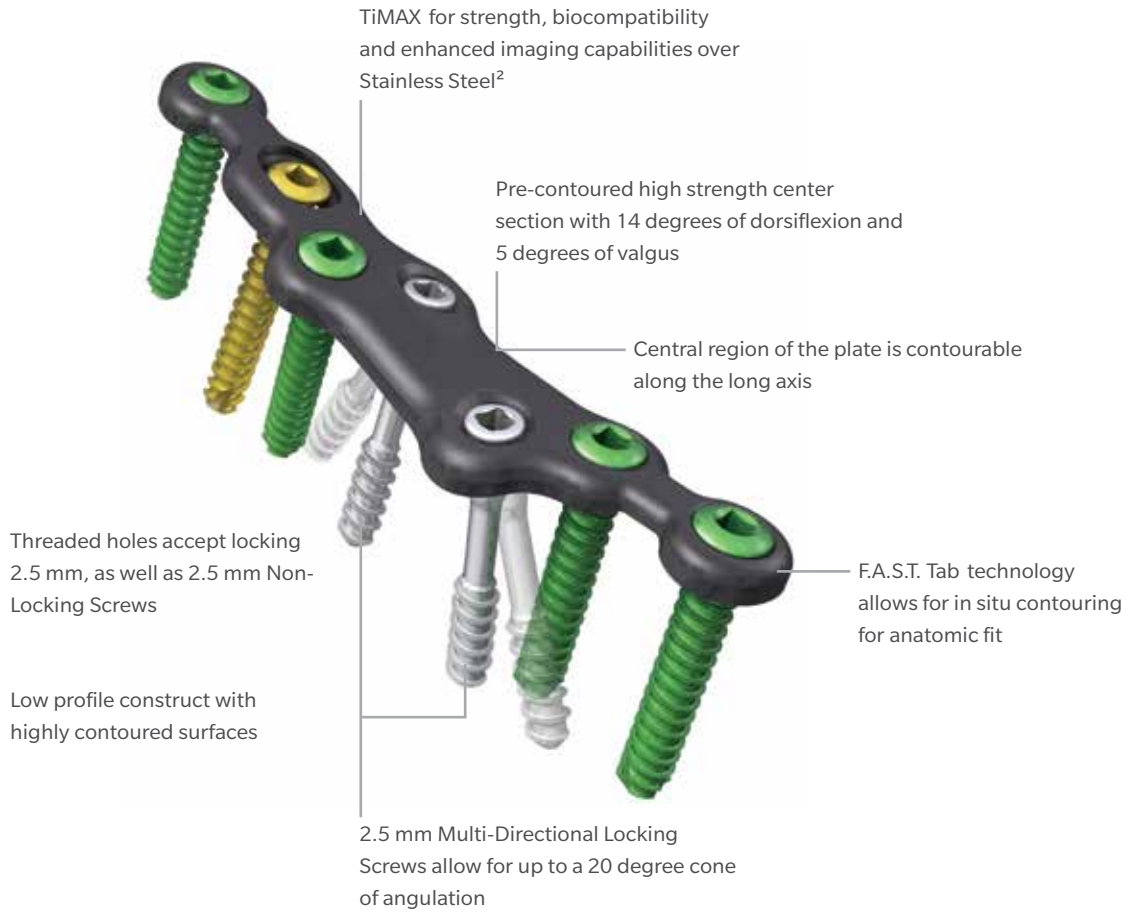

The plate has an integrated fixation corridor designed to facilitate interfragmentary screw fixation



1st Metatarsal Fusion Plate – 3.5 mm

Slotted hole allows for up to 1.25 mm of compression when used with a 3.5 mm Low Profile Non-Locking Screw

TiMAX for strength, biocompatibility and enhanced imaging capabilities over Stainless Steel²

Pre-contoured high strength center section with 7 degrees of dorsiflexion and 5 degrees of valgus

Central region of the plate is contourable along the long axis

Hole for autograft or allograft fixation to plate with Non-Locking 3.5 mm Screw

Threaded holes accept 2.7 mm and 3.5 mm Locking Screws, as well as 3.5 mm Multi-Directional Locking Screws and 3.5 mm Non-Locking Screws

Low profile construct with highly contoured surfaces

F.A.S.T. Tab technology allows for in situ contouring to match patient anatomy

3.5 mm Multi-Directional Locking Screws allow for up to a 30 degree cone of angulation

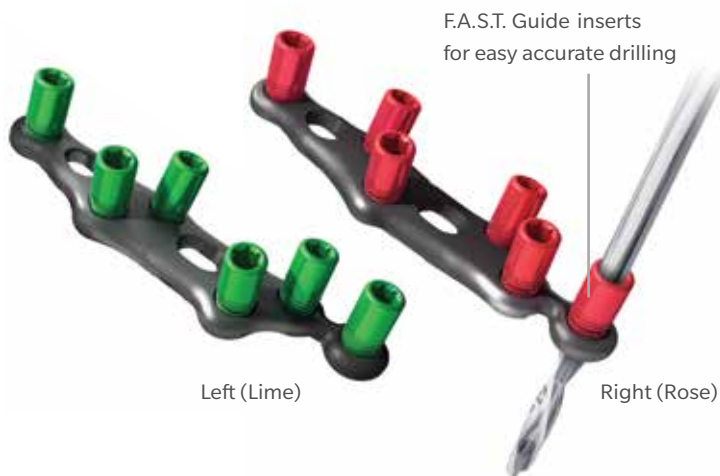

The plate has an integrated fixation corridor designed to facilitate interfragmentary screw fixation



Exposure and Plate Placement

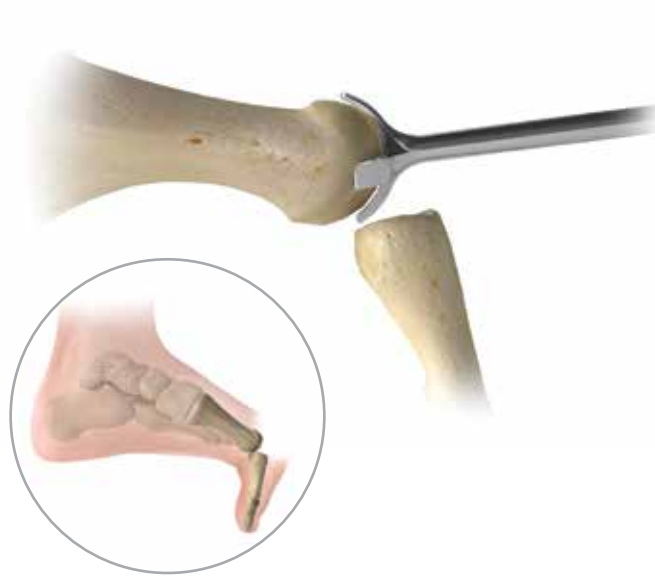

Figure 1

The following surgical technique applies to the fusion of the 1st Metatarsophalangeal (MTP) joint.

Step 1: Exposure & Alignment

Perform a longitudinal incision beginning just proximal to the interphalangeal joint and extend over the 1st MTP joint medial to the extensor hallucis longus. Expose the proximal phalanx and metatarsal head and denude all cartilage surfaces exposing the bleeding subchondral bone. If shortening of the metatarsal is a concern, place autograft or allograft within the arthrodesis site. Use a 1.6 mm K-wire (Cat. No. 14425-6) to provisionally fix the joint at the desired angle. If an interfragmentary cross screw is used, position the guide wire prior to positioning the plate.

Optional: Cup & Cone Reamers

If utilizing cup and cone reamers to prepare the joint, determine the appropriate size of cone reamer by placing it over the metatarsal head to ensure adequate coverage. Cup and cone reamers range from 14-24 mm in diameter and have an AO quick connect attachment. Place a 1.6 mm K-wire into the center of the metatarsal head and drive it proximally into the diaphysis.

Place the cone reamer over the K-wire and begin reaming until all cartilage has been denuded and bleeding subchondral bone has been exposed (Figure 1). Be sure to protect the soft tissue and sesamoids during this step.

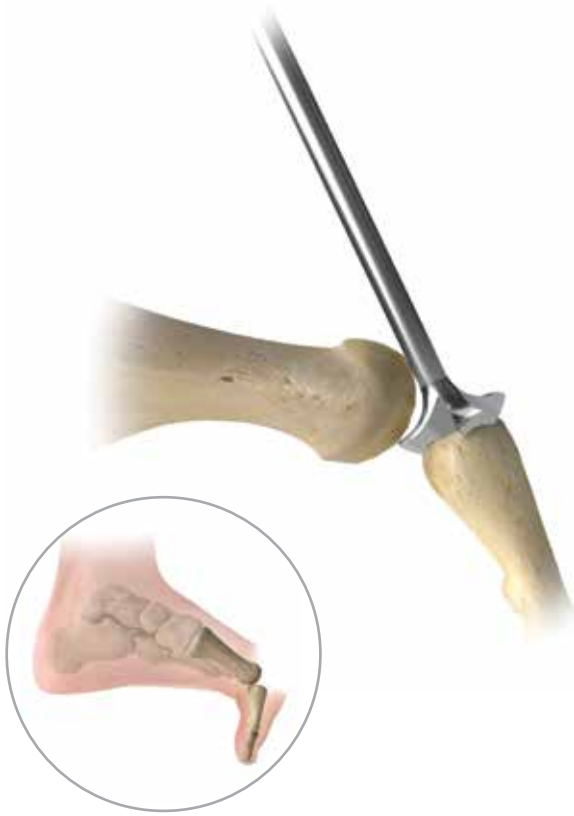

Figure 2

Optional: Cup & Cone Reamers (cont.)

To prepare the joint surface of the phalanx, utilize the same size cup reamer as was used on the metatarsal for congruent surfaces. Insert a 1.6 mm K-wire into the center of the base of the proximal phalanx and drive it distally into the phalangeal diaphysis. Place the cup reamer over the K-wire and begin reaming until all cartilage is denuded and bleeding subchondral bone has been exposed (Figure 2).

Caution: To avoid excessive reaming, the reamers should be turning at slow speed prior to contact with the bone.

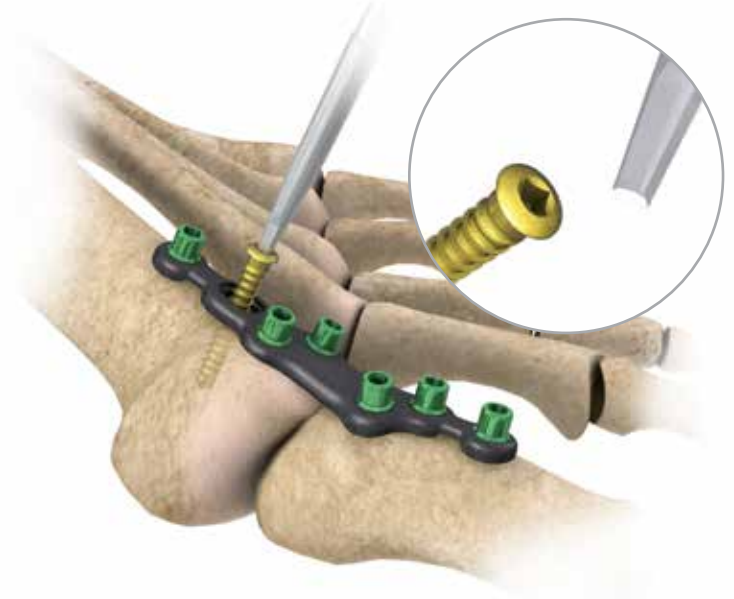

Figure 3

Step 2: Plate Placement

Small 2.5 mm 1st MTP Fusion Plate

The plate should be placed dorsally such that it permits the placement of the screws adjacent to the joint line. Partially insert a 2.5 mm Non-Locking Screw (Cat. No. SPXX000) through the oval hole of the plate to allow distal to proximal optimization of the plate (Figure 3).

Note: A detailed technique for screw insertion can be found in the 2.5 mm screw section of this technique guide.

Optional Plate Contouring



Figure 4



Figure 5

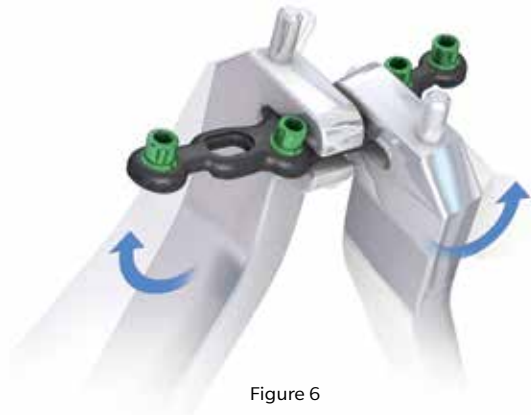

Figure 6

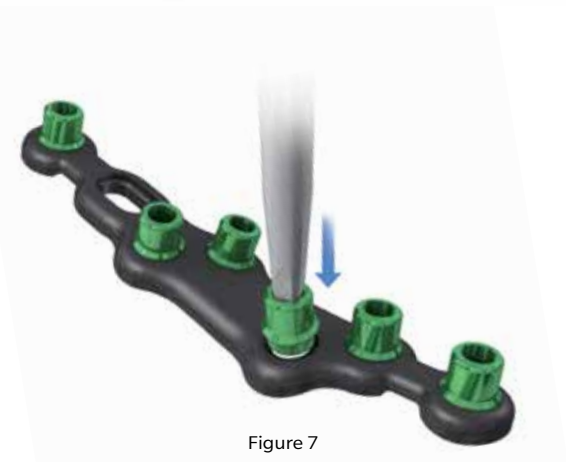

Figure 7

Step 2: Plate Placement (cont.)

Remove only the two inner most F.A.S.T. Guides from the high strength region (Figure 4).

Use the slotted end of the Double F.A.S.T. Guide Bender (Cat. No. 2142-88-005) (Figure 5).

Reduce or increase dorsiflexion angle by bending in one continuous direction only (Figure 6).

With the plate contoured, replace the F.A.S.T. Guides (Figure 7).

Note: New Plate Benders (Cat. No. 2320-12-212) are now available in the A.L.P.S. Total Foot System which no longer require the removal of F.A.S.T. Guides. These are described in detail on pages 16 and 17 of this section.

Step 2: Plate Placement (cont.)

⊖ **Note:** A detailed technique for screw insertion can be found in the 2.5 mm screw section of this technique guide.

Caution: Each bend should be in one direction only; reverse or over bending may weaken or cause plate to break.

Do not alter the flexion angle by more than 7 degrees in either direction.

⊖ **Note:** To replace the F.A.S.T. Guides and prevent possible cross threading, it is helpful to initially turn the F.A.S.T. Guide counter clockwise ¼ turn before fully inserting the F.A.S.T. Guide.

Optional Interfragmentary Screw Fixation



Figure 8



Figure 9



Figure 10

The A.L.P.S. Foot 1st MTP plate has an offset screw, which provides a convenient corridor for interfragmentary screw fixation. Figure 8 demonstrates the most suitable trajectory for the interfragmentary screw. Figure 9 demonstrates how positioning the interfragmentary screw can interfere with the plate and screw construct.

ⓘ **Note:** It is also possible to utilize the 2.5 mm Multi-Directional Locking Screw (Cat. No.1312-11-1XX) or a 2.5 mm Non-Locking Screw (Cat. No. SPXX000) to avoid the interfragmentary cross screw or joint line.

Suggestion: After placing an interfragmentary screw across the joint for compression, use fluoroscopic guidance to the plate with respect to the screw, prior to finalizing plate. (Figure 10).

Once the optimal plate has been identified, fully insert the 2.5 mm Non-Locking Screw to provisionally fix the plate to bone. With the plate provisionally fixed, proceed to Step 3.

In Situ Contouring

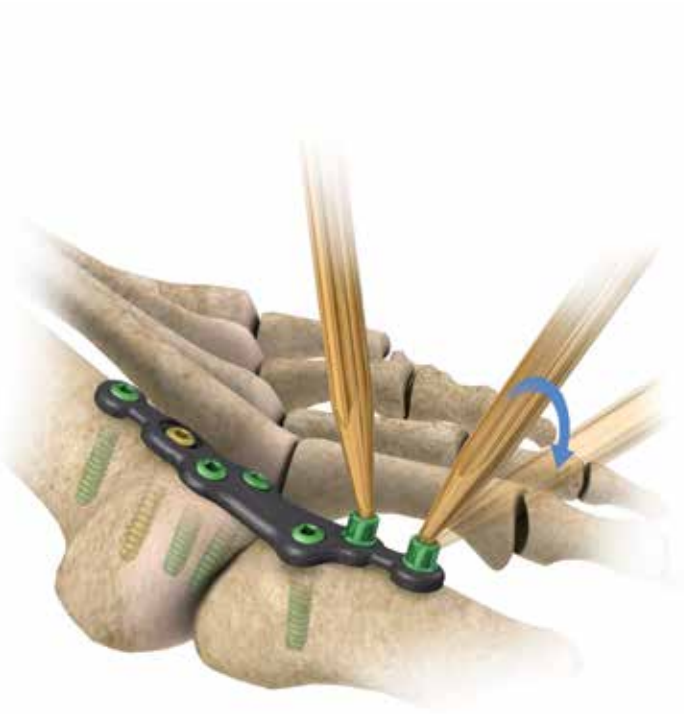

Figure 11

Step 3: In Situ Contouring

It is possible to intra-operatively contour the proximal and distal ends of the plate to establish a more patient specific fit using the Gold benders. (Cat. No. 2312-20-101 and Cat. No. 2312-20-100)

To bend the most proximal or distal node of the plate along the long axis, place the long end of the bender into the F.A.S.T. Guides of adjacent nodes. Hold one bender as an anchor and manipulate the other (Figure 11).

Screw Fixation



Figure 12

Step 4: Screw Fixation

With the plate contoured and the 2.5 mm Non-Locking Screw: (Cat. No. SPXX000) fully inserted for provisional fixation, fill the remaining holes with, 2.5 mm Locking Screws: (Cat. No. FPXX) or 2.5 mm Multi-Directional Locking Screws: or 2.5 mm Non-Locking Screws (Cat. No. SPXX000) (Cat. No. 1312-11-1xx) (Figure 12).

ⓘ **Note:** A detailed technique for screw insertion can be found in the 2.5 mm screw section of this technique guide.

Exposure and Placement



Figure 13



Figure 14



Figure 15

Step 1: Plate Placement

Large 3.5 mm 1st MTP Fusion Plate

Utilize the technique for exposure of the joint and plate alignment in the previous section for the Small 2.5 mm 1st MTP Fusion Plate.



The Large 3.5 mm A.L.P.S. 1st MTP Fusion Plate has an offset screw position, which provides a convenient corridor for interfragmentary screw fixation. Figure 13 demonstrates the most suitable trajectory for the interfragmentary screw. Figure 14 demonstrates how positioning the interfragmentary screw can interfere with the plate and screw construct.

Step 2: Plate Placement (cont.)

Note: It is also possible to utilize the 3.5 mm Multi-Directional Locking Screw to avoid the interfragmentary cross screw or joint line.

Suggestion: After placing an interfragmentary screw across the joint for compression, use fluoroscopic guidance to position the plate with respect to the screw position, prior to finalizing plate position (Figure 15).

Optional Plate Contouring

Optional Plate Contouring

ⓘ **Note:** The high strength sections of the Small and Large 1st MTP plates are pre-contoured. If bending of these sections are required for more precise anatomic fit, use the following technique to further contour the plates, prior to plate fixation.

1st MTP Fusion Plate Bending Technique

The new dedicated 1st MTP Plate Benders (Cat. No. 2312-20-212) can be utilized to contour both the Small 2.5 mm plate and the Large 3.5 mm plate, and are marked at each end with the size of plate in which it corresponds, and for both left or right plates. The F.A.S.T. Guides should not be removed, as indicated in the previous section for the Small 2.5 mm plate. Two Plate Benders are required for this function.

ⓘ **Note:** A Large 3.5 mm 1st MTP Fusion Plate (Left) will be used for the following bending steps. The larger end of the plate bender is clearly marked to accept the Large 3.5 mm plate, whereas the smaller end of the plate bender will accept the Small 2.5 mm plate.



Figure 16



Figure 17



Figure 18



Figure 19

Step 1: Slide the F.A.S.T. Guide on one end of the plate at a 45° angle into the plate bender slot marked 3.5 mm, Left (Figure 16).

Step 2: Rotate the plate parallel to the bender so that the F.A.S.T. Guide located nearest the center hole of the plate slides into the slot at the end of the bender (Figure 17).

Step 3: Using a second plate bender, from the opposite side of the plate, insert the plate into the plate bender at a 45° angle (Figure 18).

Step 4: Rotate the bender so that the center F.A.S.T. Guide slides into the slot on the end of the bender and both benders are in line, or parallel with the plate (Figure 19).

Optional Plate Contouring

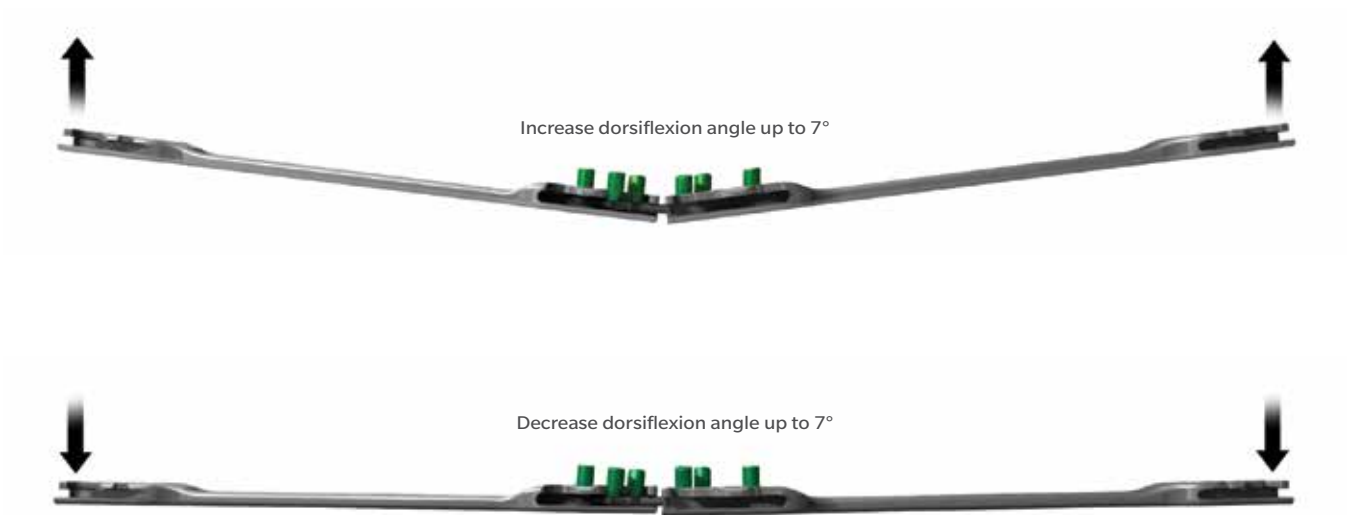

Figure 20

1st MTP Fusion Plate Bending Technique (cont.)

To increase or reduce the amount of dorsiflexion, the plate may be bent in the direction desired using the plate benders by applying pressure to the benders either upward (to increase dorsiflexion), or downward (to decrease dorsiflexion) (Figure 20).

Caution: The plate should be bent continuously no more than 7° in one direction or the other, but not both. Reverse or over bending may weaken or cause the plate to break.

ⓘ **Note:** If the new plate benders are not available in the set, utilize the technique described previously for the 2.5 mm plate, and utilize the slotted end of the Double F.A.S.T. Guide Benders (Cat. No. 2142-88-005).

In Situ Contouring and Screw Fixation



Figure 21



Figure 22

Step 2: In Situ Contouring

It is possible to intra-operatively contour the proximal and distal ends of the plate to establish a more patient specific fit using the Multi Planar Plate Benders (Cat. No. 2142-88-004).

To bend the most proximal or distal nodes of the plate along the long axis, place the long end of the bender into the F.A.S.T. Guides of adjacent nodes. Hold one bender as an anchor and manipulate the other (Figure 21).

Step 3: Screw Fixation

If additional compression is desired in addition to the compression achieved with the interfragmentary screw, the slotted compression hole can be utilized by first placing a screw in one of the three distal holes on the plate, located over the phalanx, to anchor the plate to the bone. Then insert a 3.5 mm Low Profile Non-Locking Screw into the most proximal end of the slotted compression hole following the described technique in the screw insertion section of this technique guide.







With the plate contoured and provisionally fixed to the bone, fill the remaining holes with 2.7 or 3.5 mm Locking, 3.5 mm Non-Locking, or 3.5 mm Multi-Directional Screws (Figure 22).

ⓘ **Note:** A detailed technique for screw insertion can be found in the 3.5 mm screw section of this technique guide.

1st Metatarsal Fusion Plate – 2.5 mm









Specifications & Screw Options – for 2.5 mm plate

Screw Type	Screws	Drill Bit	Handle	Driver	Depth Gauge	Length Options
Locking	 2.5 mm (Cat. No. FPXX)	Drill Bit Fast 2.0 mm (Cat. No. FDB20)	Quick Connect Handle (Cat. No. QCH)	 1.3 mm Square (Cat. No. 2312-18-012)	2.5 mm Depth Gauge (Cat. No. 2312-20-125)	8 – 40 mm
Non-Locking (Low Profile)	 2.5 mm (Cat. No. SPXX000)	Drill Bit Fast 2.0 mm (Cat. No. FDB20)	Quick Connect Handle (Cat. No. QCH)	 1.3 mm Square (Cat. No. 2312-18-012)	2.5 mm Depth Gauge (Cat. No. 2312-20-125)	8 – 40 mm
(MDTP) Multi- Directional	 2.5 mm (Cat. No. 1312-11-1XX)	Drill Bit Fast 2.0 mm (Cat. No. FDB20)	Quick Connect Handle (Cat. No. QCH)	 MDTP Driver (Cat. No. 2142-88-007)	2.5 mm Depth Gauge (Cat. No. 2312-20-125)	10 – 30 mm

1st Metatarsal Fusion Plate – 3.5 mm



Specifications & Screw Options – for 3.5 mm plate

Screw Type	Diameter Options	Drill Bit	Handle	Driver	Depth Gauge	Length Options
Locking	 3.5 mm (Cat. No. 8161-35-0XX)	2.7 mm Calibrated Drill Bit (Cat. No. 2142-27-070)	Torque Limiting (Cat. No. 2141-18-001)	 T-15 tapered (Cat. No. 2142-15-070)	Small Frag (LOCK line) (Cat. No. 2142-35-100)	10 – 50 mm
	 2.7 mm (Cat. No. 8163-27-0XX)	2.0 mm Marked Drill Bit Short (Cat. No. 2142-88-008)			 T-15 tapered (Cat. No. 2142-15-070)	
Non-Locking (Low Profile)	 3.5 mm (Cat. No. 1312-18-0XX)	2.5 mm Drill Bit (Cat. No. 8290-29-070)	Ratcheting Handle (Cat. No. 8261-66-000)	 2.2 mm Square (Cat. No. 8163-01-000)	Small Frag (NON-L line) (Cat. No. 2142-35-100)	14 – 50 mm
(MDS) Multi-Directional	 3.5 mm (Cat. No. 8163-35-0XX)	2.7 mm Calibrated Drill Bit (Cat. No. 2142-27-070)	Ratcheting Handle (Cat. No. 8261-66-000)	 2.2 mm Square (Cat. No. 8163-01-000)	Small Frag (LOCK line) (Cat. No. 2142-35-100)	20 – 50 mm



These are images of models with bones shown with plates in place and not real patients.
They are provided to show positioning and not intended to suggest immediate weight bearing.

Lapidus Plate Technique

The Lapidus Plate is designed primarily for arthrodesis of the first metatarsocuneiform joint, and is made of a titanium alloy (Ti6Al4V) with a TiMAX treatment for increased fatigue strength compared to the standard alloy.¹ The low-profile anatomic design (2 mm) and recessed screw heads minimize possible irritation to the soft tissue and skin. The Lapidus Plate provides up to 1.25 mm of compression and provides the benefits of locking technology. This plate offers numerous screw options consisting of 4.0 mm Cancellous Locking, 3.5 mm Cortical Locking, 3.5 mm Multi-Directional Locking, 2.7 mm Cortical Locking, and 3.5 mm Low Profile Non-Locking Screws.

Lapidus Plate

Open box area of the plate allows for visualization of the TMT joint when compressing

Slotted holes provide up to 1.25 mm compression per hole when used in conjunction with 3.5 mm Low Profile Non-Locking Screw

Threaded holes accept locking 2.7 mm, 3.5 mm, 4.0 mm, and 3.5 mm Multi-Directional Screws as well as 3.5 mm Low Profile Non-Locking Screws

3.5 mm Multi-Directional Locking Screws allow for up to a 30 degree cone of angulation

TiMAX for strength, biocompatibility and enhanced imaging capabilities over Stainless Steel²

F.A.S.T. Tabs can be removed by bending tab up with plate benders, and then down towards bone

F.A.S.T. Guide Adapter for provisional fixation through F.A.S.T. Guide

F.A.S.T. Guide inserts for easy accurate drilling

Double F.A.S.T. Guide Benders allow for bending along two axes

F.A.S.T. Tabs are designed to allow for bending in multiple planes

Screw heads are recessed into the plate providing an overall low profile construct with either Locking or Non-Locking Screws



Approach and Plate Placement



Figure 1

Perform a longitudinal incision either medially or dorsally over the 1st metatarsocuneiform joint. Expose the joint and denude all cartilage surfaces to expose the bleeding subchondral bone. To avoid shortening and elevation of the metatarsal, place allograft or autograft within the arthrodesis site. A guide pin may be needed to reduce the prepared joint surfaces, and a cannulated screw may be used to provide initial compression and stability of the joint prior to plate placement. The cannulated screw should be placed distal-dorsal to proximal-plantar across the metatarsocuneiform joint, and the head of the screw should be countersunk to minimize soft tissue irritation.

Step 1: Plate Placement

The plate should be placed dorsal-medially such that the joint line is centered in the middle of the open box (between the proximal three holes of the plate, and the two holes just proximal to the compression slot) to ensure that screws are sufficiently clear of the joint line prior to screw insertion (Figure 1).

Provisional Fixation

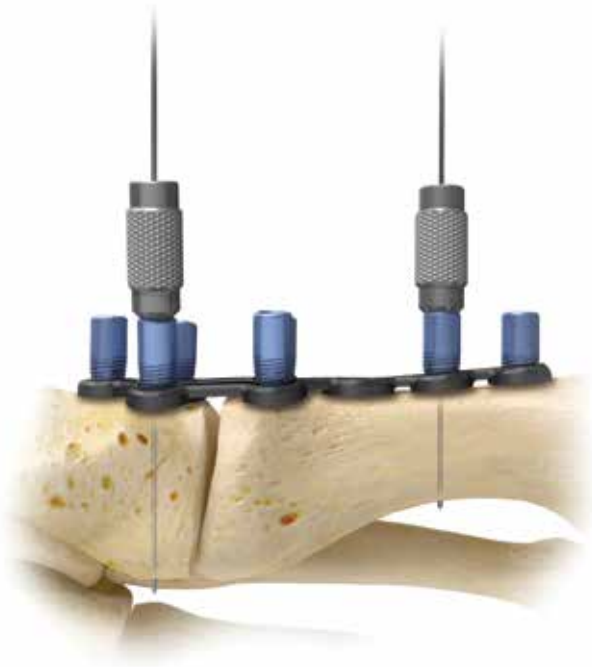

Figure 2

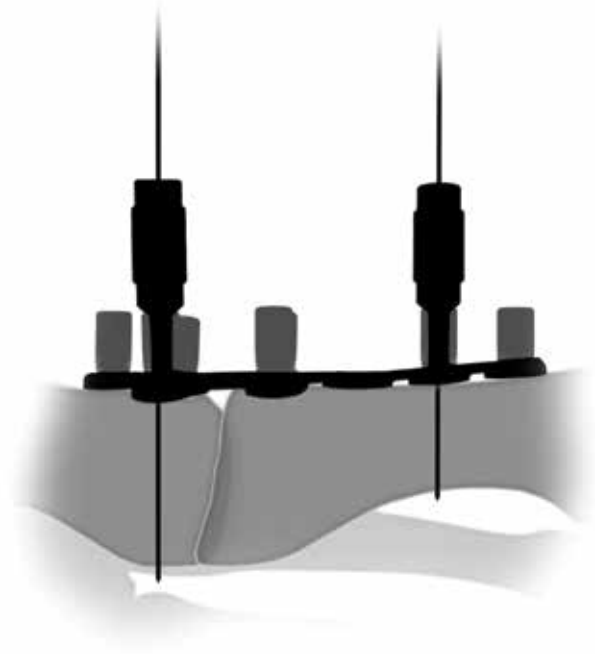

Figure 3

Step 2: Provisional Fixation

For provisional fixation, the 2.0 mm F.A.S.T. Guide Adapters (Cat. No. 2312-18-007) can convert any F.A.S.T. Guide into a K-wire fixation hole (Figure 2).

ⓘ **Note:** Provisional fixation with the 2.0 mm F.A.S.T. Guide Adapter and 2.0 mm K-wire has the added advantage of allowing the surgeon to predict the trajectory of a locking screw construct under fluoroscopy.

If the trajectory is deemed inadequate, the surgeon has several options; bend the plate intra-operatively, employ a 3.5 mm Multi-Directional Screw, or use a 3.5 mm Low-Profile Non-Locking Screw to establish a new trajectory.

Suggestion: Using fluoroscopic guidance to the Lapidus Plate can be especially helpful to ensure adequate purchase of both the Locking and Compression screws in the cuneiform and metatarsal bones (Figure 3).

In Situ Contouring



Figure 4

Step 3: In Situ Contouring

With the plate provisionally attached to the bone, it is possible to intra-operatively contour the plate to establish a more patient specific fit using the Foot Multi-Planar Bender (Cat. No. 2142-88-004) (Figure 4).



Figure 5a



Figure 5b

ⓘ **Note:** The Foot Multi-Planar Benders are double sided for use with a variety of bending techniques. The end of the plate bender with three teeth (Figure 5a), allows for bending in multiple planes.

Place the round end of the bender into the F.A.S.T. Guides of adjacent nodes. Hold the bender fixed with the round end as an anchor and manipulate the other end with either side of the benders to bend or twist along a single axis (Figure 5b).

Screw Insertion



Figure 6



Figure 7

Step 3: In Situ Contouring (cont.)

Caution: Each bend should be in one direction only; reverse or repeated bending may weaken or cause the plate to break.

The distal F.A.S.T. Tab may be cut or bent off if not needed by placing the round end of the Foot Multi-Planar Plate Bender in the last hole, and another in the hole adjacent to it, slightly bending the tab upward, and then back down towards the bone until the tab breaks off completely (Figure 6). Bending downward will minimize the possibility of a sharp edge that could cause soft tissue irritation.

Step 4: Screw Insertion

To ensure adequate load distribution, all screw holes should be filled according to the screw insertion technique section of this guide. If a combination of Locking and Non-Locking Screws will be used, Non-Locking Screws should be inserted first to secure the plate snugly to the bone (Hybrid Locking) (Figure 7).

ⓘ **Note:** A detailed technique for screw insertion can be found in the screw section of this technique guide.

Lapidus Plate

F.A.S.T. Tabs are designed to allow for bending in multiple planes







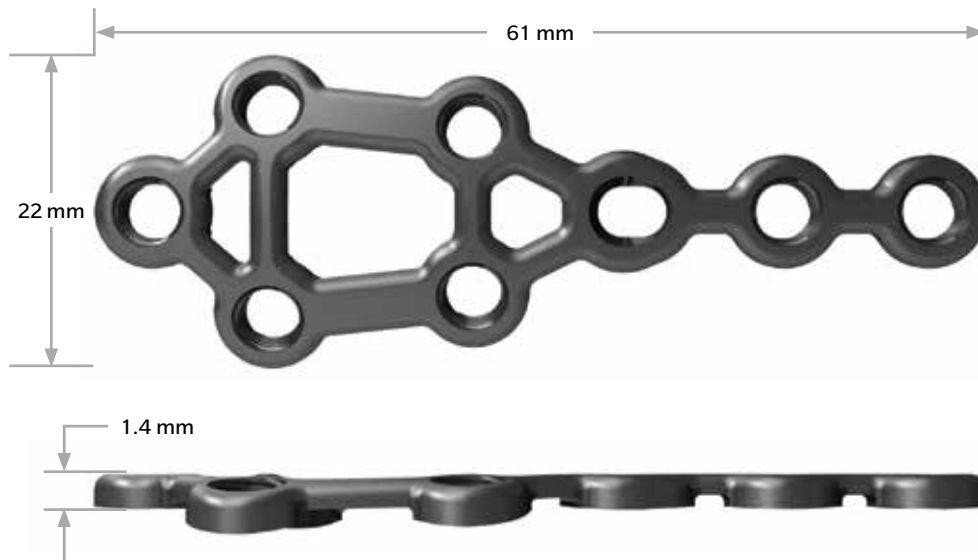



Caution: Each bend should be in one direction only; reverse or repeated bending may weaken or cause plate to break.

Lapidus Plate



Specifications & Screw Options

Screw Type	Diameter Options	Drill Bit	Handle	Driver	Depth Gauge	Length Options
Locking	 3.5 mm (Cat. No. 8161-35-0XX)	2.7 mm Calibrated Drill Bit (Cat. No. 2142-27-070)	Torque Limiting (Cat. No. 2141-18-001)	 T-15 tapered (Cat. No. 2142-15-070)	Small Frag (LOCK line) (Cat. No. 2142-35-100)	10 – 50 mm
	 4.0 mm (Cat. No. 8161-40-0XX)				2.7 mm Drill Meas Sleeve (Cat. No. 8163-01-005)	
Locking	 2.7 mm (Cat. No. 8163-27-0XX)	2.0 mm Marked Drill Bit Short (Cat. No. 2142-88-008)	Torque Limiting (Cat. No. 2141-18-001)	 T-15 tapered (Cat. No. 2142-15-070)	Small Frag (LOCK line) (Cat. No. 2142-35-100)	10 – 50 mm
					2.0 mm Drill Meas Sleeve Short (Cat. No. 2142-88-006)	
Non-Locking (Low Profile)	 3.5 mm (Cat. No. 1312-18-0XX)	2.5 mm Drill Bit (Cat. No. 8290-29-070)	Ratcheting Handle (Cat. No. 8261-66-000)	 2.2 mm Square (Cat. No. 8163-01-000)	Small Frag (NON-L line) (Cat. No. 2142-35-100)	14 – 50 mm
(MDS) Multi- Directional	 3.5 mm (Cat. No. 8163-35-0XX)	2.7 mm Calibrated Drill Bit (Cat. No. 2142-27-070)	Ratcheting Handle (Cat. No. 8261-66-000)	 2.2 mm Square (Cat. No. 8163-01-000)	Small Frag (LOCK line) (Cat. No. 2142-35-100)	20 – 50 mm

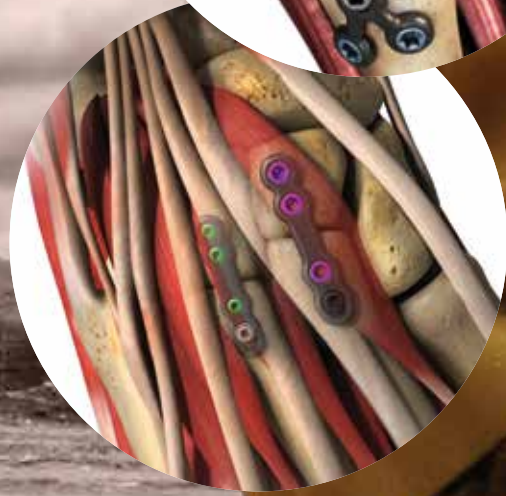

Single Joint Fusion Plate Technique:

- Compression Fusion Plate
- Closed Compression Fusion Plates
- In-Line Fusion Plates

The A.L.P.S. Single Joint Fusion family of plates are made of a titanium alloy (Ti6Al4V) with a TiMAX treatment for increased fatigue strength compared to the standard alloy.¹ The low-profile design and recessed screw heads minimize possible irritation to the soft tissue and skin.

The Single Joint Fusion family of plates contain a Compression Fusion Plate, a Small and Large Closed Compression Fusion Plate, and a Small (2.5 mm) and Large (3.5 mm) In-Line Fusion Plate, providing a wide array of options for single joint arthrodeses. Each 3.5 mm plate offers up to 1.25 mm of compression, and up to 0.5 mm of compression with the Small

2.5 mm In-Line Fusion plate when utilized with a 2.5 mm Non-Locking Screw and a washer, with all designs providing the benefits of locking technology.

These plates are designed for specific single joint arthrodeses, such as the lesser tarsometatarsal (TMT) joints, whereas plates such as the Dorsal Midfoot Fusion Plate or Medial Column Fusion Plate are designed for multiple joint arthrodesis with the use of a single plate.

The In-Line Fusion plates are generically shaped and easily contourable, and can be used in various areas of the foot and hand, in both dorsal and medial applications.

Compression Fusion Plate

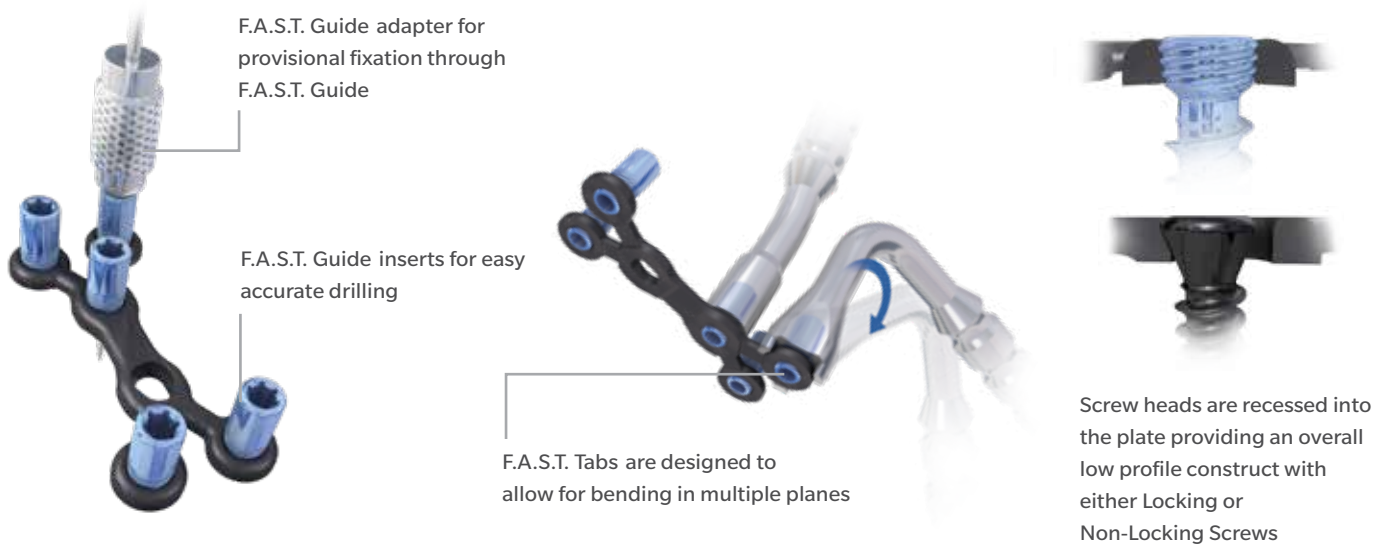

Closed Compression Fusion Plate

Slotted holes provide up to 1.25 mm compression per hole when used in conjunction with 3.5 mm Low Profile Non-locking Screw

Closed Box design provides strength

Threaded holes accept locking 2.7 mm, 3.5 mm, 4.0 mm, and 3.5 mm Multi-Directional Screws as well as 3.5 mm Low Profile Non-Locking Screws

3.5 mm Cortical Locking Screw

TiMAX for strength, biocompatibility and enhanced imaging capabilities over Stainless Steel²

4.0 mm Cancellous Locking Screw

3.5 mm Multi-Directional Locking Screws allow for up to a 30 degree cone of angulation



F.A.S.T. Tabs are designed to allow for bending in multiple planes



Screw heads are recessed into the plate providing an overall low profile construct with either Locking or Non-Locking Screws

Small 2.5 mm and Large 3.5 mm In-Line Fusion Plates

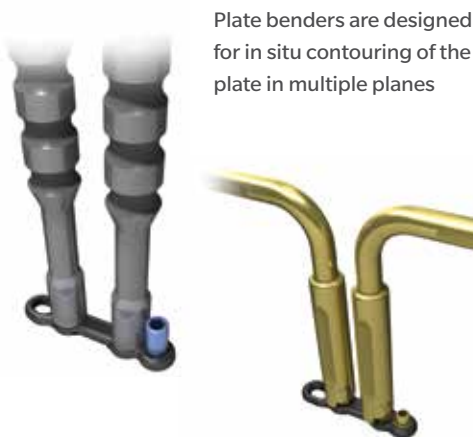

Approach and Plate Placement



Figure 1a



Figure 1b

Perform a longitudinal incision either medially or dorsally over the selected lesser metatarsocuneiform joint. Expose the joint and denude all cartilage surfaces to expose the bleeding subchondral bone. To avoid shortening and elevation of the metatarsal, place autograft or allograft within the arthrodesis site. A guide pin may be needed to reduce the prepared joint surfaces prior to plate placement.

Step 1: Plate Placement

Care should be taken to position the plate such that the joint lines are located between the center holes of the plate, to ensure screws are sufficiently clear of the joint line prior to screw insertion (Figures 1a, 1b).

Small and Large In-Line Fusion Plates

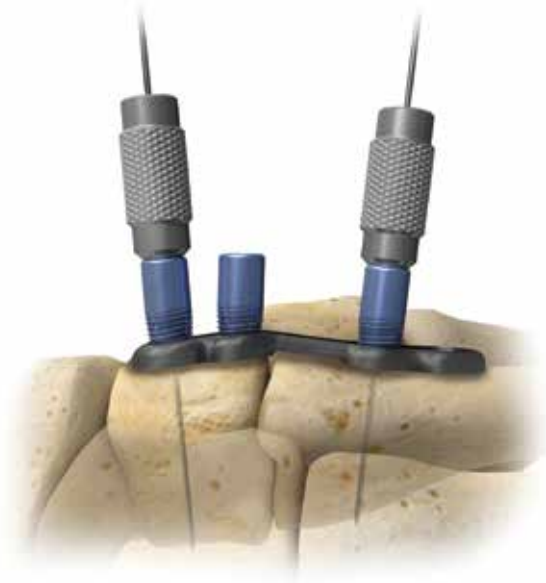

Figure 2a

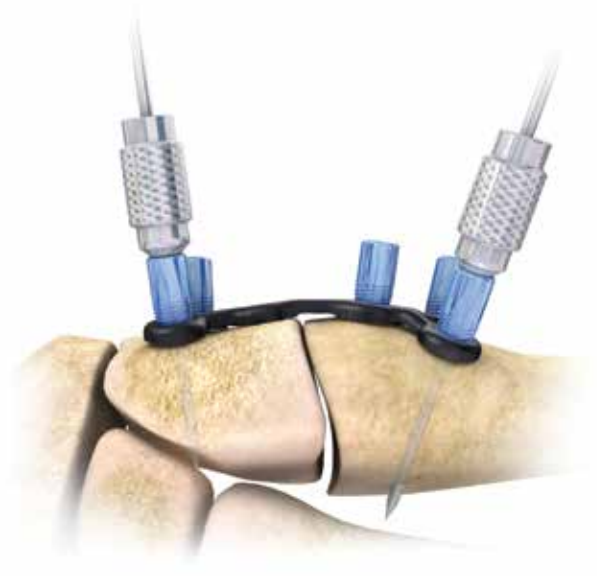

Figure 2b

Step 2: Provisional Fixation

For provisional fixation, the F.A.S.T. Guide Adapters can convert any F.A.S.T. Guide into a K-wire fixation hole (Figures 2a, 2b).

Note: Provisional fixation for a Large 3.5 mm plate using the 2.0 mm F.A.S.T. Guide Adapter (Cat. No. 2312-18-007) and a 2.0 mm K-wire (Cat. No. 141796.), or provisional fixation for a Small 2.5 mm plate using a 1.6 mm K-wire (Cat. No. 14425-6) has the added advantage of allowing the surgeon to predict the trajectory of a locking screw construct under fluoroscopy.

Small and Large In-Line Fusion Plates

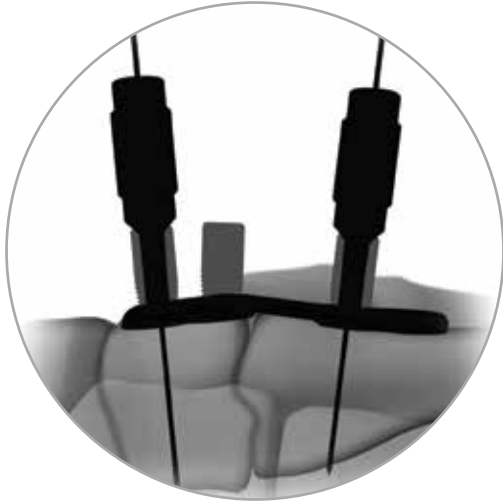

Figure 3a

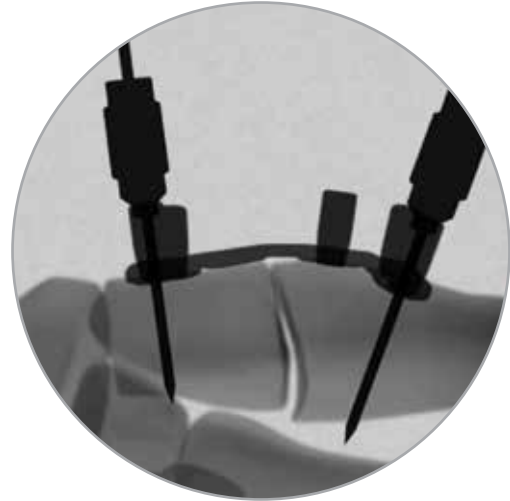
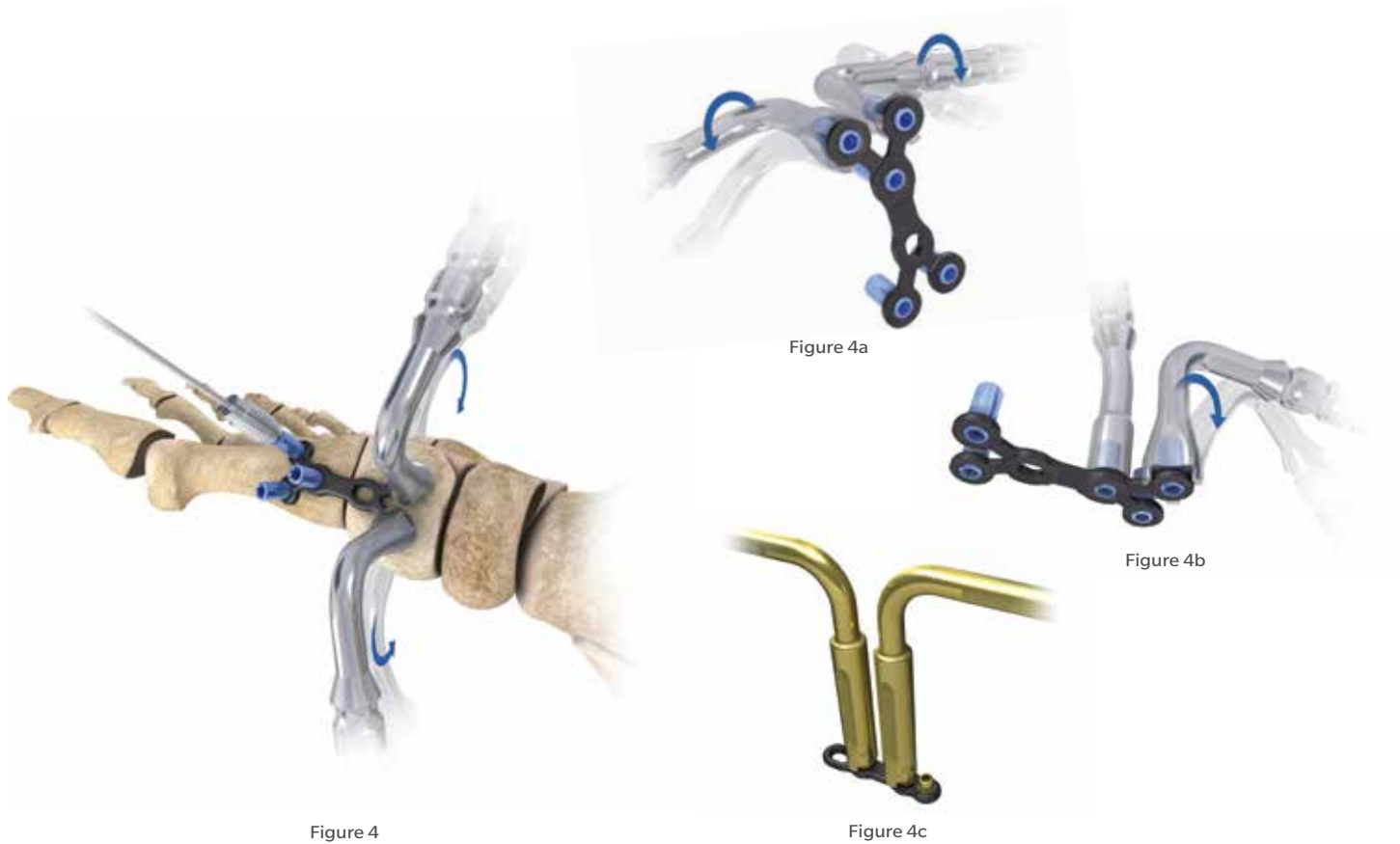

Figure 3b

If the trajectory is deemed inadequate, the surgeon has several options; bend the plate intra-operatively, employ a 3.5 mm Multi-Directional Screw, or use a 3.5 mm Low-Profile Non-Locking Screw to establish a new trajectory on a 3.5 mm plate. Utilize a 2.5 mm Multi-Directional Screw, or a 2.5 mm Non-Locking Screw with a Washer for a 2.5 mm plate.

Suggestion: Using fluoroscopic guidance to the single joint fusion family of plates can be especially helpful to ensure adequate purchase of both the Locking and Compression Screws in the cuneiforms and metatarsal bones (Figures 3a, 3b).

Approach and Plate Placement



Step 3: In Situ Contouring

With the plate provisionally attached to the bone, it is possible to intra-operatively contour the plate to establish a more patient specific fit using plate benders from the system that correspond to either the small or large plates. (Figure 4).

ⓘ **Note:** The Foot Multi-Planar Benders are double sided for use with a variety of bending techniques. The end with three teeth allows for bending in multiple planes (Figure 4a). The opposite round end, is used for single plane bending or twisting (Figure 4b).

In Situ contouring of the Small 2.5 mm In-Line Fusion Plate can be accomplished using the 2.0 mm Bending Irons (Cat. No. 2312-20-100) (Figure 4c).

Caution: Each bend should be in one direction only; reverse or repeated bending may weaken or cause plate to break.

Approach and Plate Placement



Figure 5a



Figure 5b

Step 4: Screw Insertion

To ensure adequate load distribution, all screw holes should be filled according to the screw insertion technique section of this guide. If a combination of Locking and Non-Locking Screws will be used, Non-Locking Screws should be inserted first to secure the plate snugly to bone (Hybrid Locking) (Figures 5a, 5b).

ⓘ **Note:** A detailed technique for screw insertion can be found in the screw section of this technique guide.

Single Joint Fusion Plates



In-Line Fusion Plates



Compression Fusion Plate



Closed Compression Fusion Plates

Single Joint Fusion Plates





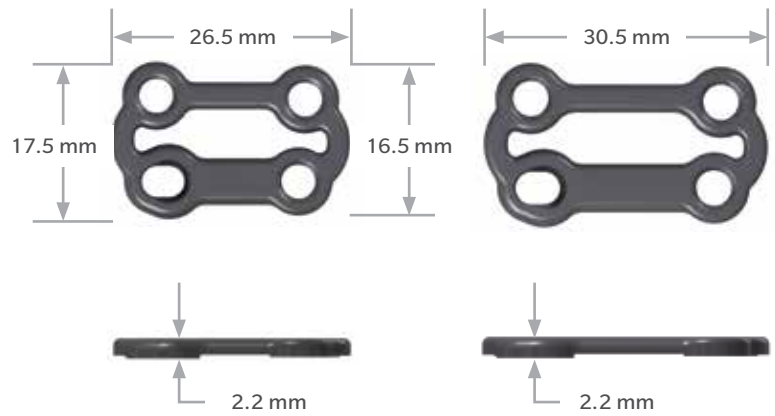





Compression Fusion Plate



Closed Compression Fusion Plate

Specifications & Screw Options





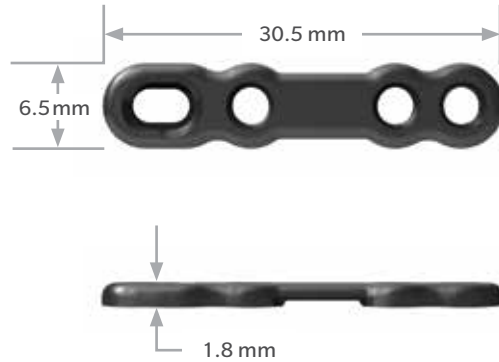

Screw Type	Diameter Options	Drill Bit	Handle	Driver	Depth Gauge	Length Options
Locking	 3.5 mm (Cat. No. 8161-35-0XX)	2.7 mm Calibrated Drill Bit (Cat. No. 2142-27-070)	Torque Limiting (Cat. No. 2141-18-001)	 T-15 tapered (Cat. No. 2142-15-070)	Small Frag (LOCK line) (Cat. No. 2142-35-100)	10 – 50 mm
	 4.0 mm (Cat. No. 8161-40-0XX)				2.7 mm Drill Meas Sleeve (Cat. No. 8163-01-005)	
	 2.7 mm (Cat. No. 8163-27-0XX)	2.0 mm Marked Drill Bit Short (Cat. No. 2142-88-008)		 T-15 tapered (Cat. No. 2142-15-070)	Small Frag (LOCK line) (Cat. No. 2142-35-100)	10 – 50 mm
2.0 mm Drill Meas Sleeve Short (Cat. No. 2142-88-006)						
Non-Locking (Low Profile)	 3.5 mm (Cat. No. 1312-18-0XX)	2.5 mm Drill Bit (Cat. No. 8290-29-070)	Ratcheting Handle (Cat. No. 8261-66-000)	 2.2 mm Square (Cat. No. 8163-01-000)	Small Frag (NON-L line) (Cat. No. 2142-35-100)	14 – 50 mm
(MDS) Multi- Directional	 3.5 mm (Cat. No. 8163-35-0XX)	2.7 mm Calibrated Drill Bit (Cat. No. 2142-27-070)	Ratcheting Handle (Cat. No. 8261-66-000)	 2.2 mm Square (Cat. No. 8163-01-000)	Small Frag (LOCK line) (Cat. No. 2142-35-100)	20 – 50 mm

Single Joint Fusion Plates



Specifications & Screw Options

In-Line Fusion Plate (Small – 2.5 mm)

Screw Type	Screws	Drill Bit	Handle	Driver	Depth Gauge	Length Options
Locking	 2.5 mm (Cat. No. FPXX)	Drill Bit Fast 2.0 mm (Cat No. FDB20)	Quick Connect Handle (Cat No. QCH)	 1.3 mm Square (Cat No. 2312-18-012)	2.5 mm Depth Gauge (Cat No. 2312-20-125)	8 – 40 mm
Non-Locking (Low Profile)	 2.5 mm (Cat. No. SPXX000)	Drill Bit Fast 2.0 mm (Cat No. FDB20)	Quick Connect Handle (Cat No. QCH)	 1.3 mm Square (Cat No. 2312-18-012)	2.5 mm Depth Gauge (Cat No. 2312-20-125)	8 – 40 mm
(MDTP) Multi- Directional	 2.5 mm (Cat. No. 1312-11-1XX)	Drill Bit Fast 2.0 mm (Cat No. FDB20)	Quick Connect Handle (Cat No. QCH)	 MDTP Driver (Cat No. 2142-88-007)	2.5 mm Depth Gauge (Cat No. 2312-20-125)	10 – 30 mm





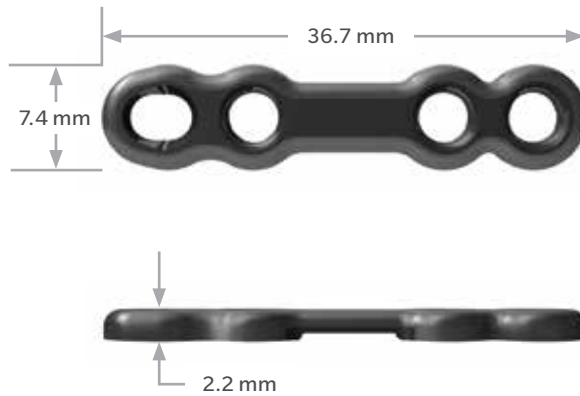



ⓘ **Note:** The 2.5 mm Compression Washer (Cat. No. 1312-20-025) is ONLY meant for use with the 2.5 mm Locking Cortical Screw.

Single Joint Fusion Plates



Specifications & Screw Options

In-Line Fusion Plate (Large – 3.5 mm)

Screw Type	Diameter Options	Drill Bit	Handle	Driver	Depth Gauge	Length Options
Locking	 3.5 mm (Cat. No. 8161-35-0XX)	2.7 mm Calibrated Drill Bit (Cat. No. 2142-27-070)	Torque Limiting (Cat. No. 2141-18-001)	 T-15 tapered (Cat. No. 2142-15-070)	Small Frag (LOCK line) (Cat. No. 2142-35-100)	10 – 50 mm
	 2.7 mm (Cat. No. 8163-27-0XX)	2.0 mm Marked Drill Bit Short (Cat. No. 2142-88-008)	Torque Limiting (Cat. No. 2141-18-001)	 T-15 tapered (Cat. No. 2142-15-070)	Small Frag (LOCK line) (Cat. No. 2142-35-100) 2.0 mm Drill Meas Sleeve Short (Cat. No. 2142-88-006)	10 – 50 mm
Non-Locking (Low Profile)	 3.5 mm (Cat. No. 1312-18-0XX)	2.5 mm Drill Bit (Cat. No. 8290-29-070)	Ratcheting Handle (Cat. No. 8261-66-000)	 2.2 mm Square (Cat. No. 8163-01-000)	Small Frag (NON-L line) (Cat. No. 2142-35-100)	14 – 50 mm
(MDS) Multi- Directional	 3.5 mm (Cat. No. 8163-35-0XX)	2.7 mm Calibrated Drill Bit (Cat. No. 2142-27-070)	Ratcheting Handle (Cat. No. 8261-66-000)	 2.2 mm Square (Cat. No. 8163-01-000)	Small Frag (LOCK line) (Cat. No. 2142-35-100)	20 – 50 mm



These are images of models with bones shown with plates in place and not real patients.
They are provided to show positioning and not intended to suggest immediate weight bearing.

Dorsal Mid-Foot Fusion Technique

The A.L.P.S. Dorsal Mid-Foot Fusion Plate (DMFP) is made of titanium alloy (Ti6Al4V) with a TiMAX treatment for increased fatigue strength compared to the standard alloy.¹ The plate is designed to fit the specific anatomic profile of the mid foot and is available in two different sizes; the small plate is designed to compress and fuse two tarsometatarsal joints, the large plate fuses two tarsometatarsal joints and has additional locking tabs for fusing the Naviculocuneiform joint. The closed box design provides strength while the integrated window improves joint access for placement of autograft or allograft within the arthrodesis site and improved postoperative visualization on x-ray versus a solid plate. The low-profile anatomic design (2 mm) and recessed screw heads minimize possible irritation of the ligaments and soft tissue. In addition to the specific anatomic design, strategic regions of the plate permit the user to contour the plate on bone with specially designed bending irons to match variations in individual patient anatomy. Each unidirectional compression slot provides up to 1.25 mm of compression and is available in both the small and large plate options (maximum compression 2.5 mm). The plate offers numerous screw options including: 4.0 mm Cancellous Locking, 3.5 mm Cortical Locking, 3.5 mm Multi-Directional Locking, 2.7 mm Cortical Locking, and 3.5 mm Low Profile Non-Locking Screws.

Dorsal Mid-Foot Fusion Plate

Threaded holes accept locking 2.7 mm, 3.5 mm, 4.0 mm, and 3.5 mm Multi-Directional Screws as well as 3.5 mm Low Profile Non-Locking Screws

Additional tabs on the Dorsal Midfoot Fusion Large provide additional points of fixation for the navicular bone and can be contoured in three planes with the Foot-Multi Planar Bender



3.5 mm Multi-Directional Locking Screws allow for up to a 30 degree cone of angulation



F.A.S.T. Tabs are designed to allow for bending in multiple planes



Double F.A.S.T. Guide Benders allow for bending along two axes

Approach and Plate Placement



Figure 1



Figure 2

The following surgical technique applies to the fusion of the 2nd and 3rd tarsometatarsal joints. This general technique can also be applied to the fusion of the 1st and 2nd tarsometatarsal joints or for fixation of a Lisfranc fracture/dislocation.

Step 1: Exposure

Perform a longitudinal incision over the 3rd metatarsocuneiform joint. Expose the 2nd and 3rd metatarsocuneiform joints and denude all cartilage surfaces exposing the bleeding subchondral bone. To avoid shortening and elevation of the metatarsals place autograft or allograft within the arthrodesis site.

Step 2: Plate Placement

Both the large and small Dorsal Midfoot Fusion plates are tapered proximal to distal, the widest segment should be positioned over the cuneiforms with the more narrow distal segment positioned over the metatarsals. Care should be taken to the plate such that the joint lines are located between the holes of the plate, to ensure screws are sufficiently clear of the joint line prior to screw insertion (Figure 1).

Suggestion: Using fluoroscopic guidance to the Small Dorsal Midfoot Fusion plate can be especially helpful to ensure adequate purchase of both the locking screws and compression screws in the cuneiform and metatarsal bones (Figure 2).

Using fluoroscopic guidance to the Large Dorsal Midfoot Fusion plate ensures that the navicular tabs are adequately centered within the navicular bone while maintaining proper alignment of the distal locking holes and compression slots within the 2nd and 3rd metatarsals.

Contouring



Figure 3

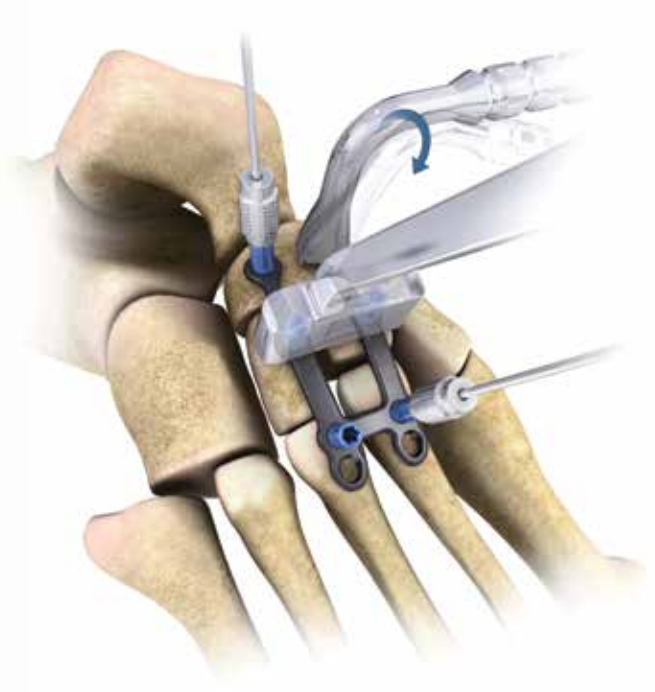

Figure 4

Step 3a: Plate Contouring

To establish a more patient specific fit, it is possible to contour the large and small Dorsal Midfoot Fusion plates using the Double F.A.S.T. Guide Bender (Cat. No. 2142-88-005) (Figure 3).

ⓘ **Note:** The Double F.A.S.T. Guide Benders are double sided for use in various bending techniques. The boxed end, shown in Figure 3, allows for concave bending in one plane. The opposite end, with a slit and post, is used for convex single plane bending across a single bridge.

Step 3b: Tab Contouring

With the plate provisionally fixed to bone, it is possible to contour the tabs of the Large Dorsal Midfoot Fusion plate in multiple planes using the Foot-Multi Planar Bender (Cat. No. 2142-88-004) and the Double F.A.S.T. Guide Bender (Cat. No. 2142-88-005) (Figure 4).

ⓘ **Note:** The Foot Multi-Planar Benders are double sided for use in various bending techniques. The bender end with three teeth, shown in Figure 4, allows for bending in multiple planes. The opposite end of the bender is used for single plane bending.

Caution: Each bend should be in one direction only; reverse or over bending may weaken or cause plate to break.

ⓘ **Note:** The Dorsal Midfoot Fusion Small Template (Cat. No. 2142-74-001) and Dorsal Midfoot Fusion Large Template (Cat. No. 2142-74-003) can be useful in assessing the plate to bone contour prior to inserting the plate onto the bone.

Provisional Fixation

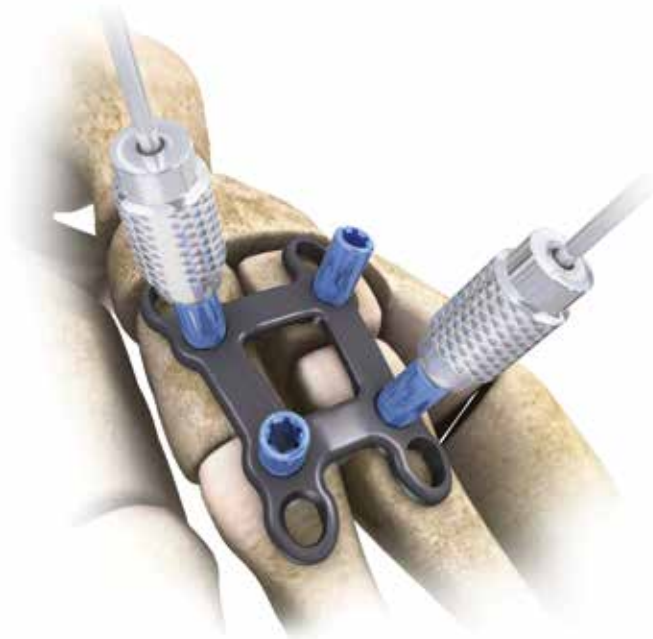

Figure 5



Figure 6

Step 4: Provisional Fixation

For provisional fixation, the 2.0 mm F.A.S.T. Guide adapters (Cat. No. 2312-18-007) can convert any F.A.S.T. Guide into a K-wire fixation hole (Figure 5).

Suggestion: Obtaining two points of provisional fixation with the F.A.S.T. Guide adapters has the added advantage of allowing the surgeon to accurately predict the trajectory of a locking screw construct under fluoroscopic guidance (Figure 6).

If a trajectory is deemed inadequate, the surgeon has two options; employ a 3.5 mm Multi-Directional Screw or utilize a 3.5 Low-Profile Non-Locking screw.

Screw Insertion (Non-Locking, Compression)

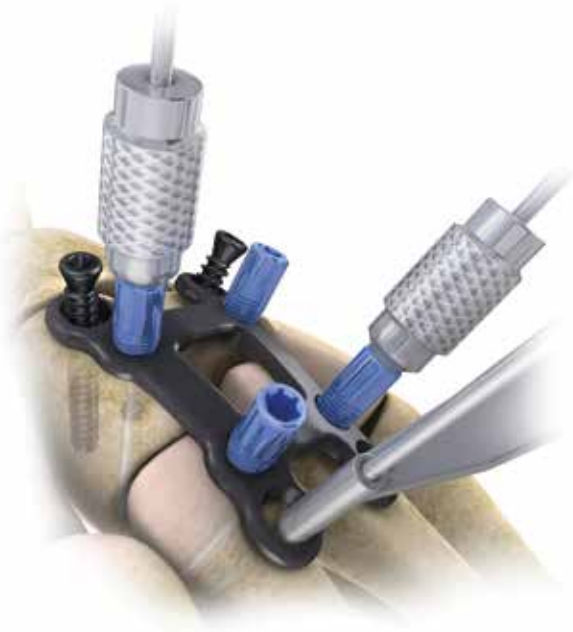

Figure 7



Figure 8

Step 5: Non-Locking Screw Insertion (Compression)

To obtain maximum compression with the Small Dorsal Midfoot Fusion Plate, partially insert 3.5 mm Low Profile Non-Locking screws into all four of the unidirectional compression slots using the following series of steps.

Place the 2.5 mm end of the 2.5/3.5 mm Drill Guide (Cat.No. 8241-96-000) eccentrically in the narrowest portion of the unidirectional slot and drill through both cortices using the 2.5 mm Drill Bit (Cat. No. 8290-29-070) (Figure 7).

Identify the appropriate screw length by using the Small Fragment Depth Gauge (Cat.No. 2142-35-100) and taking a direct reading from the NON-L (Non-Locked) line (Figure 8).



Figure 9

Partially advance the screw using the black ratchet handle (Cat. No. 8261-66-000) with the 2.2 mm Square Driver (Cat. No. 8163-01-000) being careful not to engage the screw head with the plate (Figure 9).



Figure 10



Figure 11

Once each unidirectional compression slot is filled with a partially inserted 3.5 mm Low Profile Non-Locking Screw: First, remove all provisional fixation components (Figure 10). Next, fully insert each 3.5 mm Low Profile Non-Locking Screw one by one (Figure 11).

ⓘ **Note:** A detailed technique for screw insertion can be found in the screw section of this technique guide.

Screw Insertion (Locking)



Figure 12 – Small Plate



Figure 13 – Large Plate

Step 6

Fill the remaining locking holes with locking screws in each corner to complete the locking construct (Figure 12 and 13).

ⓘ **Note:** A detailed technique for screw insertion can be found in the screw section of this technique guide.



Dorsal Midfoot Fusion Plates











Dorsal Midfoot Fusion Large Plate



Dorsal Midfoot Fusion Small Plate

Specifications & Screw Options

Screw Type	Diameter Options	Drill Bit	Handle	Driver	Depth Gauge	Length Options
Locking	 3.5 mm (Cat. No. 8161-35-0XX)	2.7 mm Calibrated Drill Bit (Cat. No. 2142-27-070)	Torque Limiting (Cat. No. 2141-18-001)	 T-15 tapered (Cat. No. 2142-15-070)	Small Frag (LOCK line) (Cat. No. 2142-35-100)	10 – 50 mm
	 4.0 mm (Cat. No. 8161-40-0XX)				2.7 mm Drill Meas Sleeve (Cat. No. 8163-01-005)	
Locking	 2.7 mm (Cat. No. 8163-27-0XX)	2.0 mm Marked Drill Bit Short (Cat. No. 2142-88-008)	Torque Limiting (Cat. No. 2141-18-001)	 T-15 tapered (Cat. No. 2142-15-070)	Small Frag (LOCK line) (Cat. No. 2142-35-100)	10 – 50 mm
					2.0 mm Drill Meas Sleeve Short (Cat. No. 2142-88-006)	
Non-Locking (Low Profile)	 3.5 mm (Cat. No. 1312-18-0XX)	2.5 mm Drill Bit (Cat. No. 8290-29-070)	Ratcheting Handle (Cat. No. 8261-66-000)	 2.2 mm Square (Cat. No. 8163-01-000)	Small Frag (NON-L line) (Cat. No. 2142-35-100)	14 – 50 mm
(MDS) Multi- Directional	 3.5 mm (Cat. No. 8163-35-0XX)	2.7 mm Calibrated Drill Bit (Cat. No. 2142-27-070)	Ratcheting Handle (Cat. No. 8261-66-000)	 2.2 mm Square (Cat. No. 8163-01-000)	Small Frag (LOCK line) (Cat. No. 2142-35-100)	20 – 50 mm



These are images of models with bones shown with plates in place and not real patients.
They are provided to show positioning and not intended to suggest immediate weight bearing.

Lateral Column Lengthening Plate Technique: Calcaneal Cuboid Joint and Calcaneal Osteotomy

The A.L.P.S. Lateral Column Lengthening Plates (LCLP) are made of a titanium alloy (Ti6Al4V) with a TiMAX treatment for increased fatigue strength compared to the standard alloy.¹ The Lateral Column Lengthening plates are designed to be used with either calcaneal osteotomy or calcaneocuboid arthrodesis lengthening procedures. The implants are available in four different sizes - a no wedge, 8 mm wedge, 10 mm wedge or 12 mm wedge. The low-profile anatomic design (2 mm) and recessed screw heads minimize possible irritation of the peroneal tendons and skin. In addition, the plate's profile has been designed with multiple radii of curvature to further minimize the possibility of tendon irritation. The wedges are tapered dorsal to plantar to minimize the possibility of an unnatural tilt of the cuboid. The wedges are also tapered laterally to medially for a more anatomically correct wedge shape. The wedge plates have also been designed to maintain ample space for the application of autograft or allograft materials.

Compression Fusion Plate



Four different sizes to choose from:

- No wedge
- 8 mm wedge
- 10 mm wedge
- 12 mm wedge

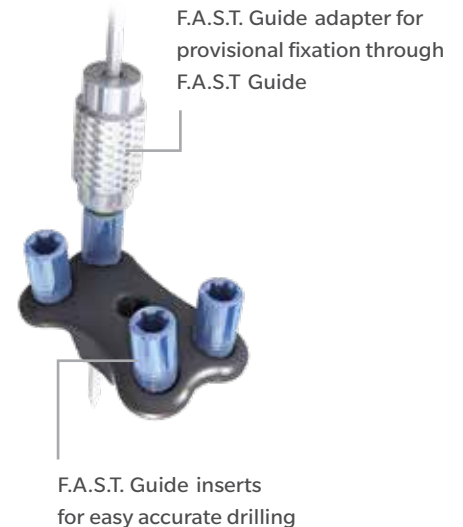

Approach and Plate Placement

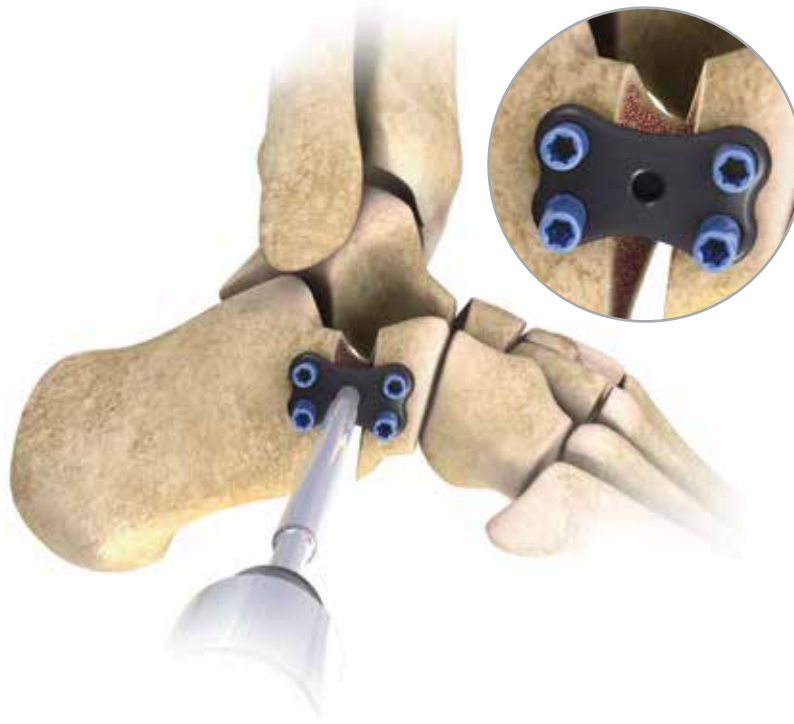

Figure 1

The following surgical technique applies to the Evans lateral column lengthening osteotomy. This general technique can also be applied to other lateral column lengthening procedures of the foot such as a calcaneocuboid joint distraction for a lateral column lengthening procedure.

Step 1: Approach

Make an oblique incision, just proximal to the calcaneocuboid joint and 1 cm below the tip of the fibula. Take care to avoid the intermediate dorsal cutaneous and sural nerves and to protect and retract the peroneal tendons. Using a blunt retractor, continue dissection and exposure with the release of dorsal and plantar soft tissue from the planned osteotomy site.

Step 2: Osteotomy and Plate Placement

Next, perform the osteotomy usually 1 to 1.2 cm proximal to the calcaneocuboid joint. With the osteotomy properly distracted to between 8 and 12 mm, choose the appropriate plate. If the lateral column lengthening wedge plate is used, ensure that the wedge sides are in close contact with either side of the joint surface (Figure 1). The T-15 Taper driver (Cat. No. 2142-15-070) can be used in to aid in plate insertion (Figure 1).

- ⓘ **Note:** The widest portion of the wedge should be placed dorsally to minimize the possibility of an unnatural tilt of the cuboid.
- ⓘ **Note:** The Lateral Column Lengthening family of plates are not designed with flexible plating technology. Therefore, the F.A.S.T. Guide inserts are intended for fast and accurate drilling purposes only and cannot be used for bending purposes.

Provisional Fixation

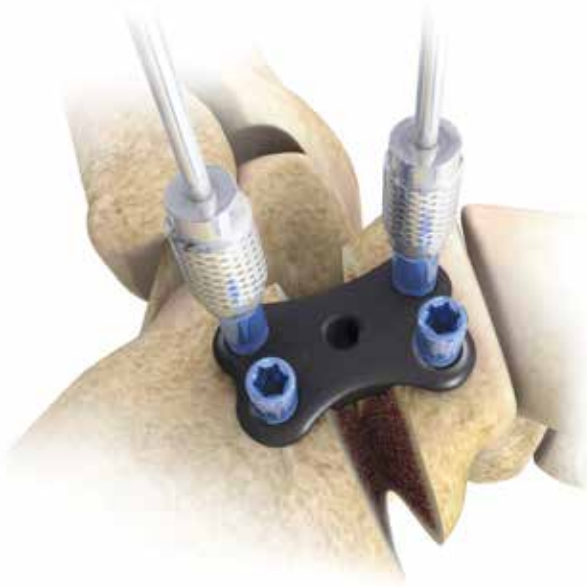

Figure 2



Figure 3

Step 3: Provisional Fixation

For provisional fixation, the 2.0 mm F.A.S.T. Guide adapters (Cat. No. 2312-18-007) can convert any F.A.S.T. Guide into a K-wire fixation hole (Figure 2).

- Note:** Provisional fixation has the added advantage of allowing the surgeon to accurately predict the trajectory of a locking screw construct under fluoroscopic guidance (Figure 3).

Screw Insertion

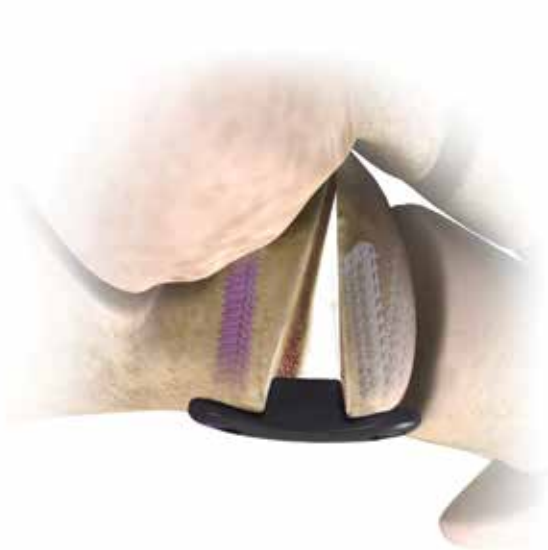

Figure 4



Figure 5

If a trajectory is deemed inadequate (Figure 3), the surgeon has two options; employ a 3.5 Low-Profile Non-Locking Screw or a 3.5 mm Multi-Directional Screw as demonstrated in Figure 4.

ⓘ **Note:** It is helpful to have two points of fixation prior to attempting to remove F.A.S.T. Guides from the lateral column (Figure 5).

Screw Insertion



Figure 6



Figure 7

Step 4: Screw Insertion

If a combination of locking and non-locking screws will be used, Non-Locking Screws should be inserted first to secure the plate in close apposition to bone.

All screw holes should be filled to ensure adequate load distribution of the locking construct and plate to bone fixation (Figure 6).





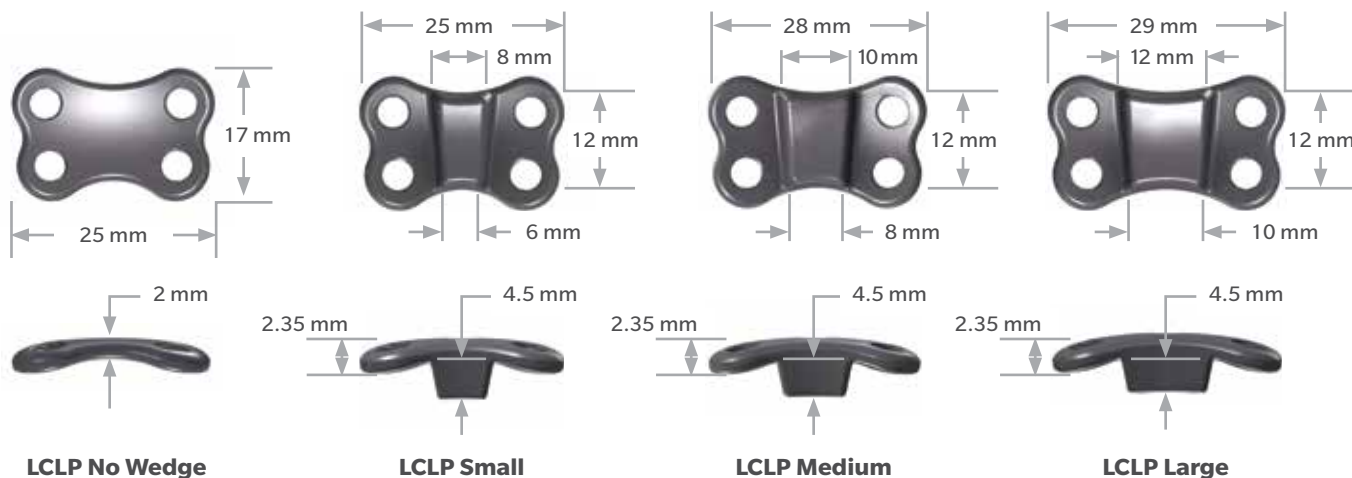



- ⓘ **Note:** The trajectories of the locking holes in the plate are designed not to interact at lengths up to 26 mm. In addition, the trajectories aim away from the plate center, helping to avoid screws passing through the joint or osteotomy site (Figure 7).
- ⓘ **Note:** A detailed technique for screw insertion can be found in the screw section of this technique guide.

Lateral Column Lengthening Plate



Note: Plate profile, length and width matches LCLP Small plate size.

Specifications & Screw Options

Screw Type	Diameter Options	Drill Bit	Handle	Driver	Depth Gauge	Length Options
Locking	 3.5 mm (Cat. No. 8161-35-0XX)	2.7 mm Calibrated Drill Bit (Cat. No. 2142-27-070)	Torque Limiting (Cat. No. 2141-18-001)	 T-15 tapered (Cat. No. 2142-15-070)	Small Frag (LOCK line) (Cat. No. 2142-35-100)	10 – 50 mm
	 4.0 mm (Cat. No. 8161-40-0XX)				2.7 mm Drill Meas Sleeve (Cat. No. 8163-01-005)	
Locking	 2.7 mm (Cat No. 8163-27-0XX)	2.0 mm Marked Drill Bit Short (Cat. No. 2142-88-008)	Torque Limiting (Cat. No. 2141-18-001)	 T-15 tapered (Cat. No. 2142-15-070)	Small Frag (LOCK line) (Cat. No. 2142-35-100)	10 – 50 mm
					2.0 mm Drill Meas Sleeve Short (Cat. No. 2142-88-006)	
Non-Locking (Low Profile)	 3.5 mm (Cat. No. 1312-18-0XX)	2.5 mm Drill Bit (Cat. No. 8290-29-070)	Ratcheting Handle (Cat. No. 8261-66-000)	 2.2 mm Square (Cat. No. 8163-01-000)	Small Frag (NON-L line) (Cat. No. 2142-35-100)	14 – 50 mm
(MDS) Multi-Directional	 3.5 mm (Cat. No. 8163-35-0XX)	2.7 mm Calibrated Drill Bit (Cat. No. 2142-27-070)	Ratcheting Handle (Cat. No. 8261-66-000)	 2.2 mm Square (Cat. No. 8163-01-000)	Small Frag (LOCK line) (Cat. No. 2142-35-100)	20 – 50 mm



These are images of models with bones shown with plates in place and not real patients.
They are provided to show positioning and not intended to suggest immediate weight bearing.

Medial Column Fusion Technique

The A.L.P.S. Medial Column Fusion Plate (MCF) is made of titanium alloy (Ti6Al4V) with a TiMAX treatment for increased fatigue strength compared to the standard alloy.¹ It has an anatomical shape corresponding to the anatomy of the navicular, medial cuneiform and first metatarsal. The low-profile anatomic design (2 mm) and recessed screw heads minimize potential irritation of the ligaments and soft tissue. In addition to the specific anatomic design, strategic regions of the plate permit the user to contour the plate to bone after provisional fixation to match variations in individual patient anatomy. The implant is designed to provide up to 1.25 mm of compression in both the naviculo-cuneiform and tarso-metatarsal joints. The Medial Column Fusion (MCF) plate offers numerous screw options; 4.0 mm Cancellous Locking, 3.5 mm Cortical Locking, 3.5 mm Multi-Directional Locking, 2.7 mm Cortical Locking, and 3.5 mm Low Profile Non-Locking Screws.

Medial Column Fusion Plate

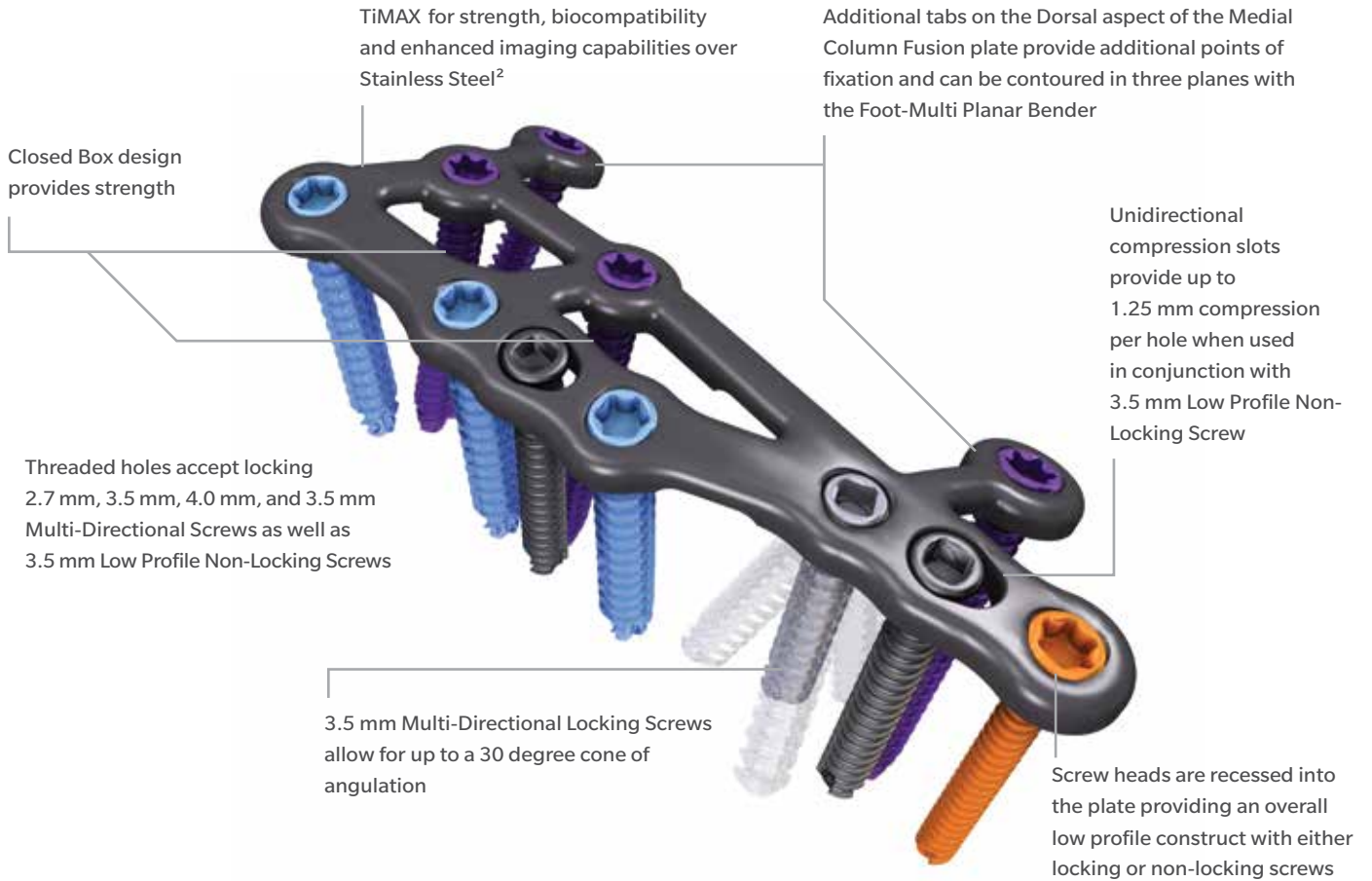

Left (Lime)

F.A.S.T. Guide adapter for provisional fixation through F.A.S.T. Guide

F.A.S.T. Tabs are designed to allow for bending in multiple planes

F.A.S.T. Guide inserts for easy accurate drilling

Double F.A.S.T. Guide benders allow for bending along one plane

Right (Rose)

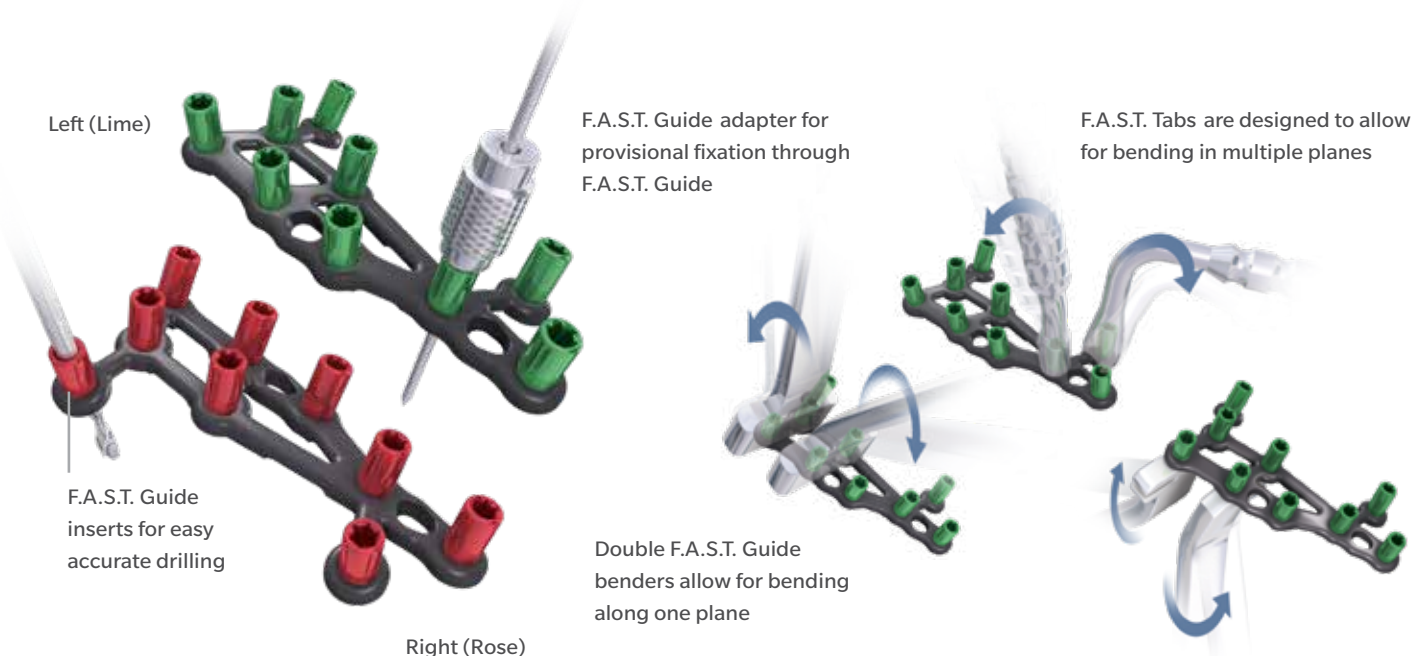

Approach and Plate Placement



Figure 1

Step 1: Exposure

Perform a longitudinal incision medially extending from the proximal border of the navicular to the shaft of the first metatarsal. Expose and denude the cartilage surfaces of both the naviculo-cuneiform and the tarso-metatarsal joints, exposing the bleeding subchondral bone. To avoid shortening and elevation of the first ray, place adequate autograft or allograft within the arthrodesis site. A guide pin may be used to maintain bony alignment prior to plate placement.

Note: Depending on surgeon preference and exposure of the anterior tibial tendon, the surgeon has two options; resect and reattach the tendon after plate placement or dissect and spare the tendon by sliding the plate under the anterior tibial tendon.

If the anterior tibial tendon is dissected and spared, it is recommended to pre-contour the plate and remove the 5 most distal F.A.S.T. Guides prior to inserting the plate beneath the tendon.

Step 2: Plate Placement

The plate should be positioned medially and extend from the navicular, across the medial cuneiform to the first metatarsal. If compression is desired, care should be given to ensure that the two unidirectional compression slots are located within the medial cuneiform and the first metatarsal, and that the screws are sufficiently clear of the joint line prior to screw insertion (Figure 1).

Plate Contouring

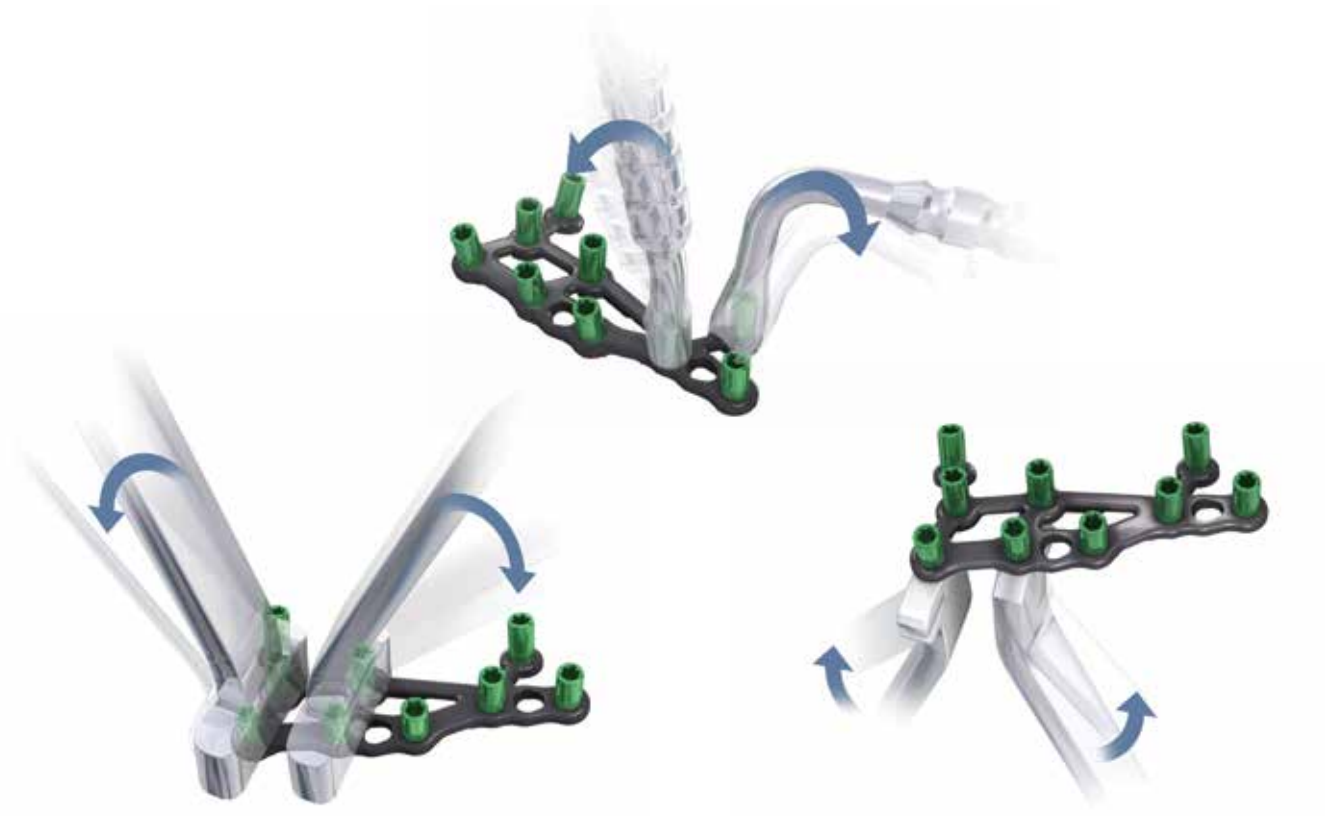

Figure 2

Figure 3

Step 3: Plate Contouring

Suggestion: Precontouring the Medial Column Fusion Plate can be difficult. Therefore, it is helpful to obtain the general anatomic profile of the medial surfaces of navicular, medial cuneiform and first metatarsal bones using the Medial Column Fusion bending template (Cat. No. 2142-76-101) (Figure 2).

With the template removed, match the anatomic profile with the Medial Column Fusion plate using either the Double F.A.S.T. Guide Benders (Cat. No. 2142-88-005) for bending along a single plane or Multi Planer benders (Cat. No. 2142-88-004) when bending in multiple planes.

ⓘ **Note:** The Double F.A.S.T. Guide Benders are double sided for use in various bending techniques. The boxed end, shown in Step 3a, allows for convex bending in one plane. The opposite end, with a slit and post, is used for concave single plane bending.

ⓘ **Note:** Concave uni planar bending using the reverse bending nodes of the Double F.A.S.T. Guide Bender (Figure 3).

Caution: Each bend should be in one direction only; reverse or over bending may weaken or cause plate to break.

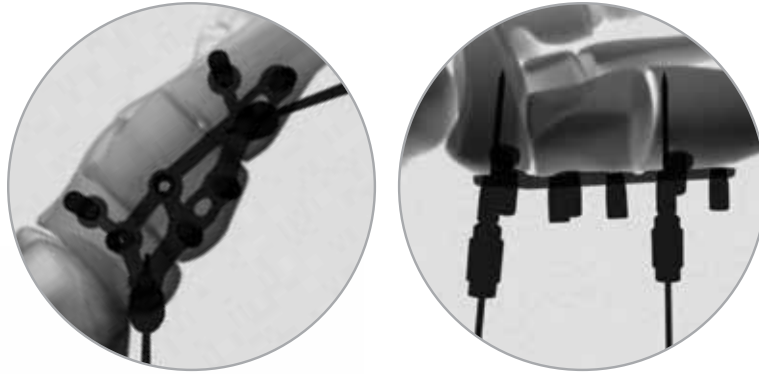

Figure 5

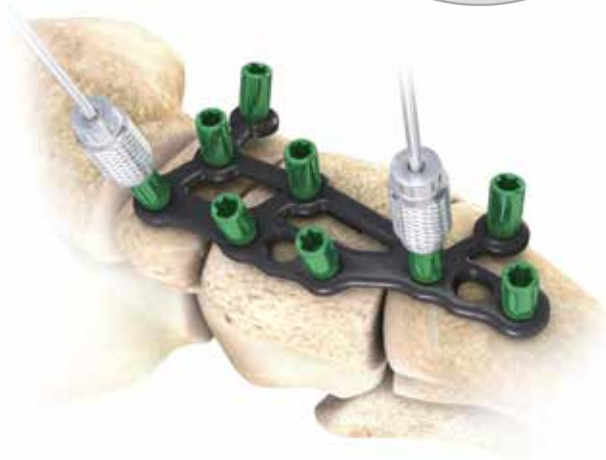

Figure 4

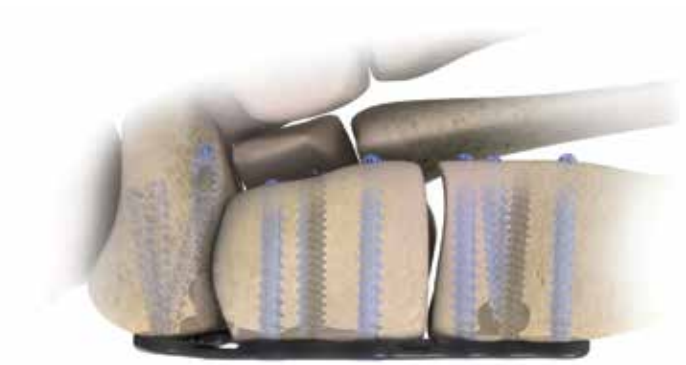

Figure 6

Step 4: Provisional Fixation

For provisional fixation, the 2.0 mm F.A.S.T. Guide adapters (Cat. No. 2312-18-007) can convert any F.A.S.T. Guide into a K-wire fixation hole (Figure 4).

⊖ **Note:** Provisional fixation with the 2.0 mm F.A.S.T. Guide adapter and 2.0 mm K-wire has the added advantage of allowing the surgeon to accurately predict the trajectory of a locking screw construct under fluoroscopy.

If the trajectory is deemed inadequate, the surgeon has several options; bend the plate intra-operatively, employ a 3.5 mm Multi-Directional Screw, or use a 3.5 Low-Profile Non-Locking Screw to establish a new trajectory.

Suggestion: Using fluoroscopic guidance to the Medial Column Fusion plate can be especially helpful to ensure that the Unidirectional Compression Slots are within the borders of the medial cuneiform and first metatarsal bones while still maintaining adequate purchase within the navicular bone (Figure 5).

⊖ **Note:** Natural variations in the navicular bone make identifying screw trajectories especially important when positioning the medial column fusion plate. It is often necessary assess the trajectory of the most posterior inferior screw and insert a 3.5 mm Multi-Directional Screw in order to avoid the talonavicular joint (Figure 6).

In Situ Contouring

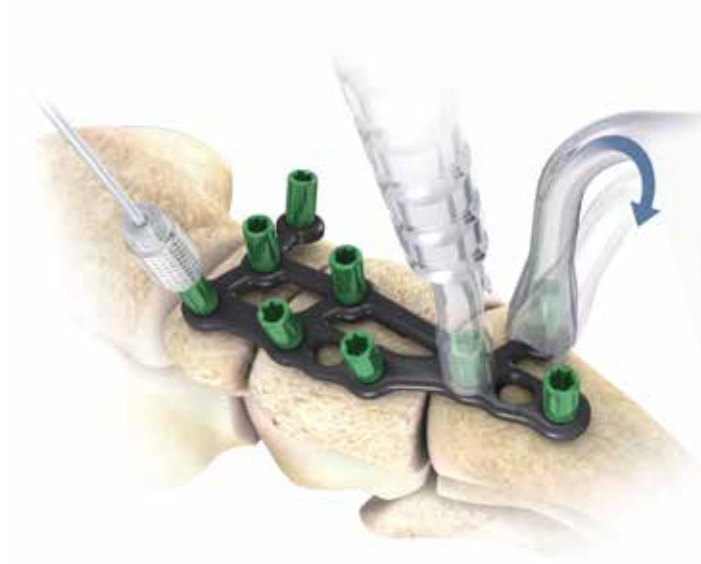

Figure 7

Step 5: Contour To Bone

With the plate provisionally fixed, it is also possible to further contour the plate to bone for a more patient specific fit using the Foot-Multi Planar Bender (Cat. No. 2142-88-004).

The Foot Multi-Planar Benders are double sided for use in various bending techniques. The end with three teeth allows for bending in multiple planes. The opposite end, is used for single plane bending or twisting (Figure 7).

Caution: Each bend should be in one direction only; reverse or over bending may weaken or cause plate to break.

Screw Insertion (Locking and Non-Locking)

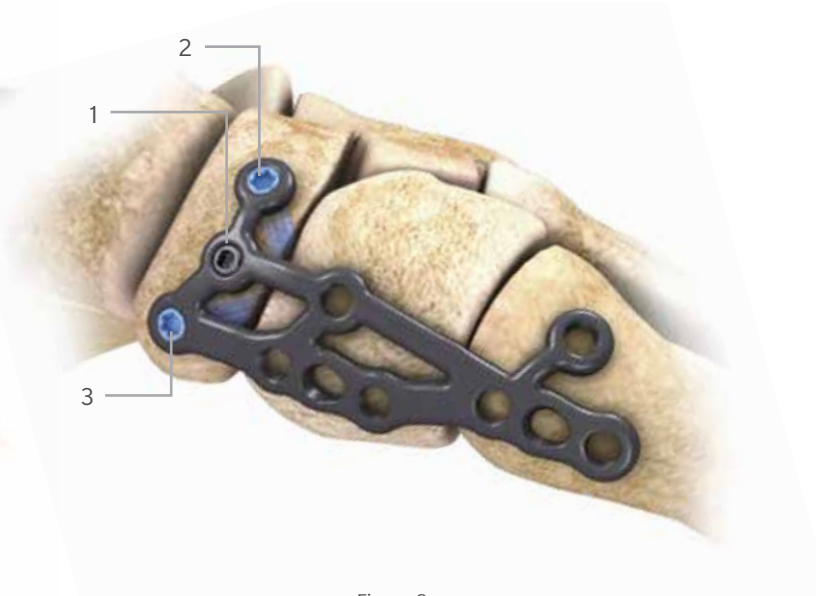

Figure 8

Step 6: Screw Insertion (Locking and Non-Locking)

To obtain up to 1.25 mm of compression across both the naviculo-cuneiform and tarso-metatarsal joints using the Medial Column Fusion Plate, sequentially fix and compress each joint beginning with the naviculocuneiform joint using the following series of steps.

ⓘ **Note:** A detailed technique for screw insertion can be found in the screw section of this technique guide.

Reduce and fix the plate to the navicular bone by: First, placing a Non-Locking Screw in the center hole of the navicular section. Next, fix the plate to the navicular bone by obtaining at least two cortices of fixation with the remaining locking screw holes (Figure 8).



Figure 9



Figure 10

Compress the naviculocuneiform joint by fully inserting a 3.5 mm Non-Locking Screw in the unidirectional compression slot located over the medial cuneiform (Figure 9).

Fix the plate to the medial cuneiform by obtaining at least two cortices of fixation with the locking screws (Figure 10).

Screw Insertion (Locking and Non-Locking)



Figure 11

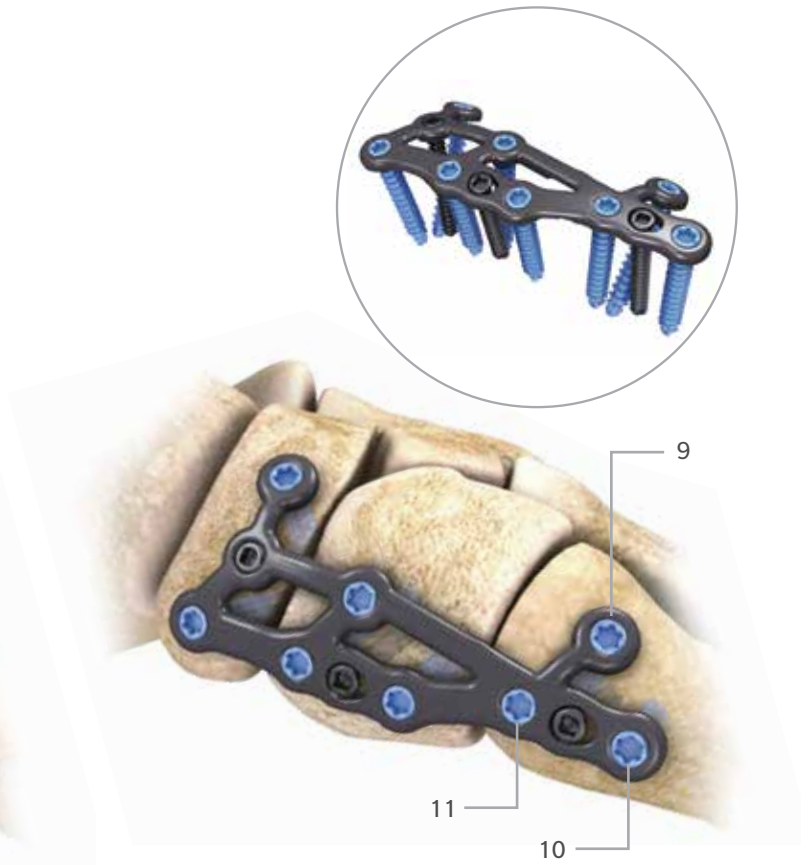

Figure 12

Step 6: Screw Insertion (Locking and Non-Locking) (cont.)









Compress the Tarsometatarsal joint by fully inserting a 3.5 mm Non-Locking Screw in the unidirectional compression slot located over the 1st metatarsal (Figure 11).

Fix the plate to the metatarsal by obtaining at least two cortices of fixation with the locking screws (Figure 12).

Medial Column Fusion Plate



Specifications & Screw Options

Screw Type	Diameter Options	Drill Bit	Handle	Driver	Depth Gauge	Length Options
Locking	 3.5 mm (Cat. No. 8161-35-0XX)	2.7 mm Calibrated Drill Bit (Cat. No. 2142-27-070)	Torque Limiting (Cat. No. 2141-18-001)	 T-15 tapered (Cat. No. 2142-15-070)	Small Frag (LOCK line) (Cat. No. 2142-35-100)	10 – 50 mm
	 4.0 mm (Cat. No. 8161-40-0XX)				2.7 mm Drill Meas Sleeve (Cat. No. 8163-01-005)	
	 2.7 mm (Cat No. 8163-27-0XX)	2.0 mm Marked Drill Bit Short (Cat. No. 2142-88-008)		 T-15 tapered (Cat. No. 2142-15-070)	Small Frag (LOCK line) (Cat. No. 2142-35-100)	10 – 50 mm
		2.0 mm Drill Meas Sleeve Short (Cat. No. 2142-88-006)				
Non-Locking (Low Profile)	 3.5 mm (Cat. No. 1312-18-0XX)	2.5 mm Drill Bit (Cat. No. 8290-29-070)	Ratcheting Handle (Cat. No. 8261-66-000)	 2.2 mm Square (Cat. No. 8163-01-000)	Small Frag (NON-L line) (Cat. No. 2142-35-100)	14 – 50 mm
(MDS) Multi-Directional	 3.5 mm (Cat. No. 8163-35-0XX)	2.7 mm Calibrated Drill Bit (Cat. No. 2142-27-070)	Ratcheting Handle (Cat. No. 8261-66-000)	 2.2 mm Square (Cat. No. 8163-01-000)	Small Frag (LOCK line) (Cat. No. 2142-35-100)	20 – 50 mm



These are images of models with bones shown with plates in place and not real patients. They are provided to show positioning and not intended to suggest immediate weight bearing.

Locking Calcaneal Plate Technique

The A.L.P.S. Locking Calcaneal Plate is made of a titanium alloy (Ti6Al4V) with a TiMAX treatment for increased fatigue strength compared to the standard alloy.¹ This locking plate offers a high strength, low profile design that closely matches the anatomy of the calcaneus. The anatomical shape of the plate is further enhanced by pre-described screw trajectories corresponding to the anatomy of the subtalar joint. The plate is available in two different sizes with right and left options. Its thickness is 2.5 mm, with reduced bridge thickness between screws to facilitate contouring to the bone. The prescribed trajectory of the most superior locking screw is angled downward to closely match the geometry of the articular surface for subarticular support while minimizing the potential of penetrating the posterior articular facet. The two adjacent locking screws have trajectories that angle superiorly into the sustentaculum to support the middle facet. The plate offers numerous screw options including: 4.0 mm Cancellous Locking, 3.5 mm Cortical Locking, 3.5 mm Multi-Directional Locking, 2.7 mm Cortical Locking, and 3.5 mm Low Profile Non-Locking Screws.

Locking Calcaneal Plate

Closed Box perimeter design provides strength

Pre-contoured anatomical design with screw trajectories corresponding to the anatomy of the subtalar joint

TiMAX for strength, biocompatibility and enhanced imaging capabilities over Stainless Steel²

Threaded holes accept Locking 2.7 mm, 3.5 mm, 4.0 mm, and 3.5 mm Multi-Directional Screws as well as 3.5 mm Low Profile Non-Locking Screws

3.5 mm Multi-Directional Locking Screws allow for up to a 30 degree cone of angulation

Screw heads are recessed into the plate providing an overall low profile construct with either Locking or Non-Locking Screws



F.A.S.T. Guide adapter for provisional fixation through F.A.S.T. Guide

Left (Lime)

Offered in right and left with large and small size options

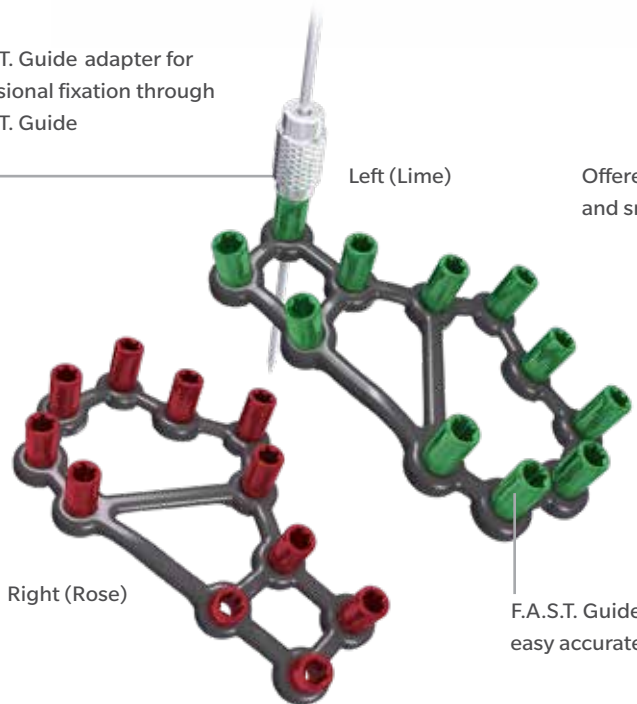

Right (Rose)

F.A.S.T. Guide inserts for easy accurate drilling

F.A.S.T. Tabs are designed to allow for In-Situ Contouring

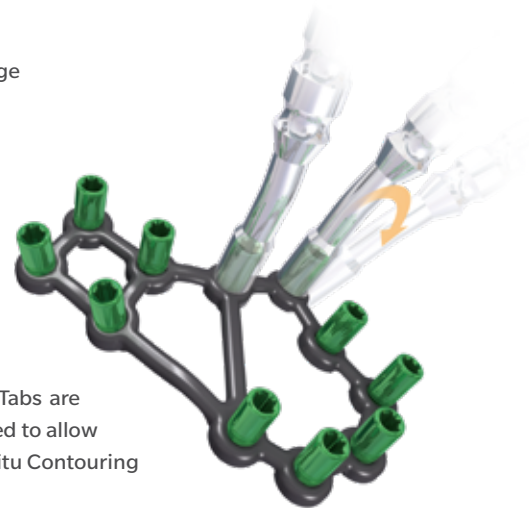

Approach, Reduction and Plate Placement

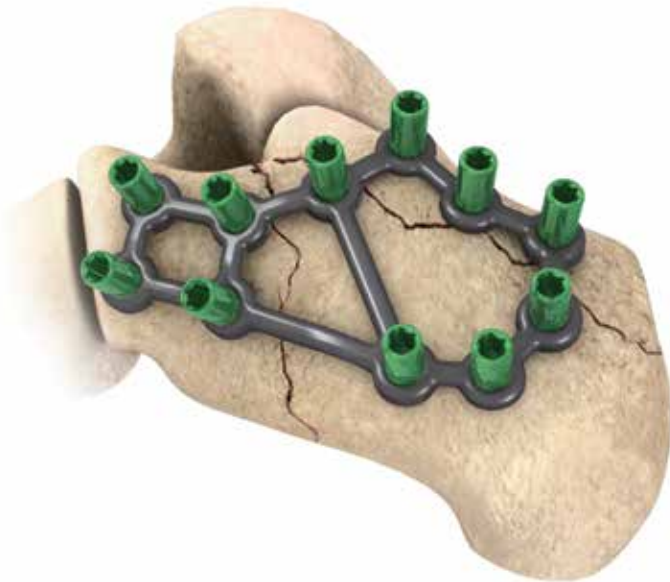

Figure 1



Figure 2

Step 1: Approach

The calcaneus is approached through an extensile lateral incision which minimizes the sequelae of peroneal tendinitis and devascularization of the anterior skin flap, as well as preserving the sural nerve which should be entirely within the flap. The calcaneo-fibular ligament is taken with the flap. The full thickness flap is then retracted using the “no touch” technique by the use of three K-wires, one up the fibular shaft, one in the talar neck and one in the cuboid. Next, a short Schanz pin is inserted into the calcaneus at posterior inferior corner of the wound to be used as a handle for subsequent reduction.

Step 2: Reduction and Plate Placement

After adequate exposure and irrigation of hematoma, the fracture should be reduced and provisionally stabilized with K-wires. The subtalar reduction is verified on a fluoroscopic mortise view of the ankle, and again with the foot externally

rotated, into the supine and dorsiflexed. A modified Harris heel view is then obtained to verify that the heel is out of varus. Once reduction is verified, the plate is sized and positioned on the lateral surface such that the most superior F.A.S.T. Guide lies just under the posterior articular facet and the most superior anterior F.A.S.T. Guide is positioned just in line with the anterior superior portion of the anterior articular facet (Figure 1). Final verification of plate size and placement is easily confirmed under fluoroscopy (Figure 2).

Note: The Calcaneal Bending Templates (Small Cat. No. 2142-08-001; Large Cat. No. 2142-08-003) can be useful in determining plate to bone contouring and size prior to inserting the plate onto the bone.

With the template removed, match the anatomic profile using either the Double F.A.S.T. Guide Benders for bending along a single plane or Multi Planer Benders when bending in multiple planes.

Provisional Fixation

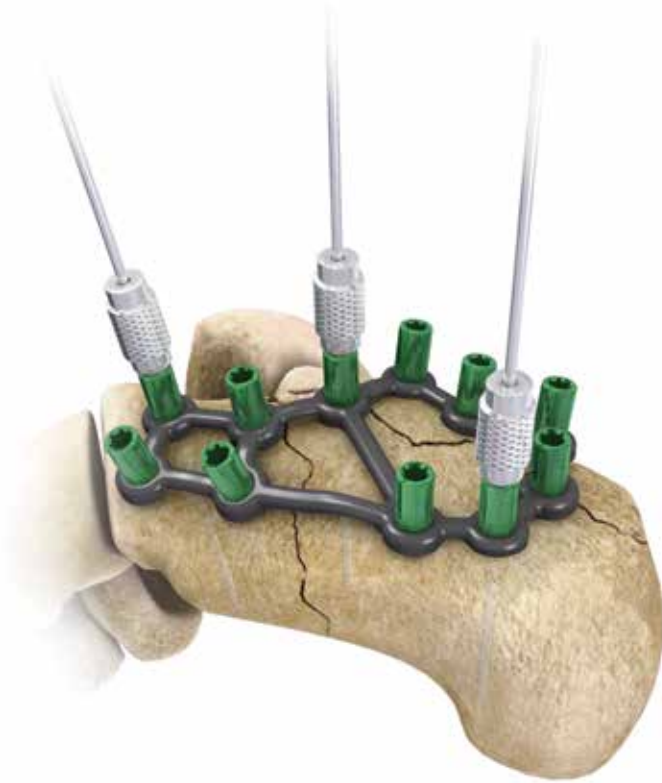

Figure 3

Step 3: Provisional Fixation

For provisional fixation with a K-wire, the 2.0 mm F.A.S.T. Guide adapters (Cat. No. 2312-18-007) can convert any F.A.S.T. Guide into a K-wire fixation hole.

Provisional fixation has the added advantage of allowing the surgeon to predict the trajectory of a plate/screw construct relative to important articular structures with fluoroscopy. If a trajectory is deemed inadequate, the surgeon has several options; bend the plate intra-operatively, employ a 3.5 mm Multi-Directional Screw, or use a 3.5 Low-Profile Non-Locking Screw to establish a new trajectory.

Suggestion: Provisional fixation should be obtained at three points, one in the anterior facet, one in the portion of the plate under the posterior tuberosity and one in the portion of the plate that sits underneath the posterior facet.

Non-Locking Screw Insertion

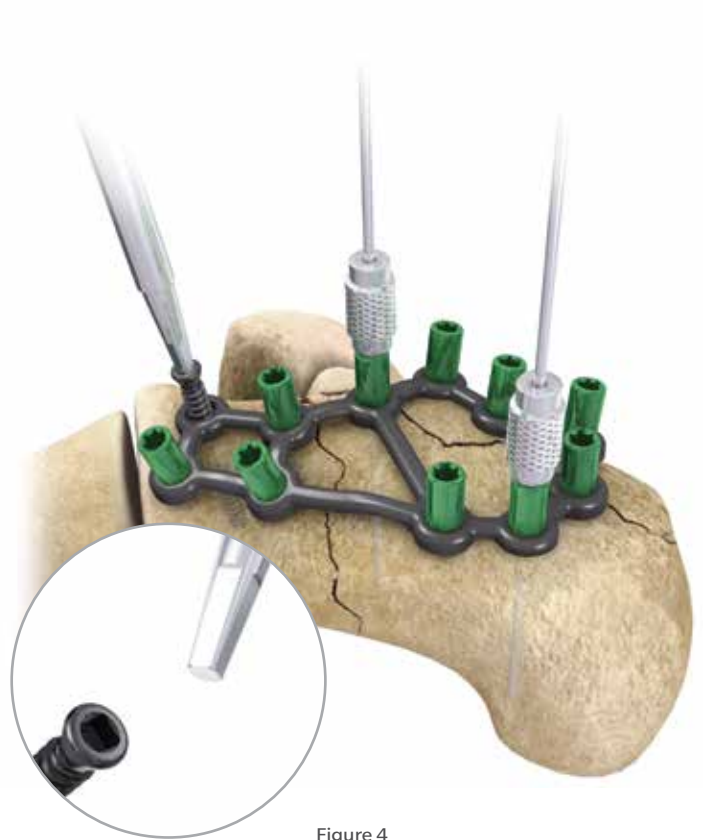

Figure 4

Step 4: Non-Locking Screw Fixation

With the plate provisionally fixed at three points, exchange the three provisional points of fixation with 3.5 mm Low Profile Non-Locking Screws to reduce the plate to bone (Step 4 and 5).

ⓘ **Note:** A detailed technique for screw insertion can be found in the Small Frag screw section of this technique guide.

In Situ Contouring

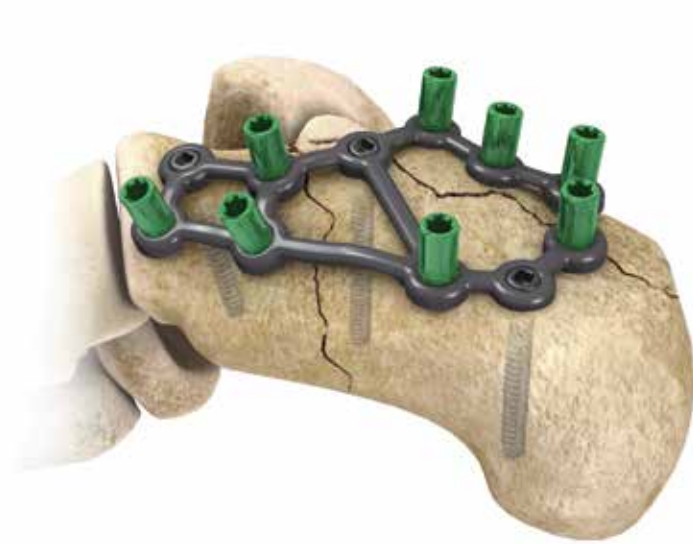

Figure 5



Figure 6

Step 5: In Situ Contouring

With the plate reduced to bone with Non-Locking Screws, it is rarely necessary to further contour the plate. If this is required however, it can be performed using the Foot-Multi Planar Bender (Cat. No. 2142-88-004).

ⓘ **Note:** The Locking Calcaneal Plate is designed to be contoured along a single axis. Therefore, only the end of the bender without tabs can be used when contouring or adjusting the plate and screw trajectories. In addition, only one bridge section should be contoured at a time (Figure 6).

Caution: Each bend should be in one direction only; reverse or over bending may weaken or cause the plate to break.

Screw Insertion (Non-Locking, Compression)



Figure 7

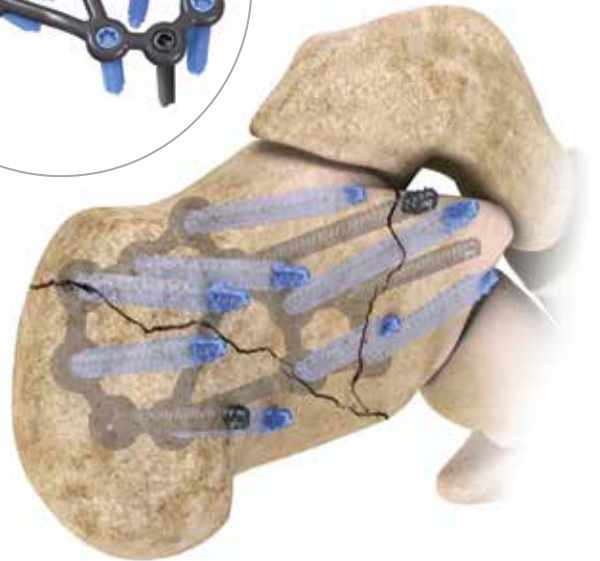

Figure 8

Step 6: Locking Screw Fixation

Additional locking screws can then be placed as needed to secure the fracture (Figure 7).

- ⊖ **Note:** The anatomical shape of the plate is further enhanced by pre-described screw trajectories corresponding to the anatomy of the subtalar joint line. While the trajectories are directed at the sustentaculum tali, these trajectories can be further refined with either 3.5 mm Multi-Directional Locking Screws or 3.5 mm Low Profile Non-Locking Screws (Figure 8).
- ⊖ **Note:** A detailed technique for screw insertion can be found in the screw section of this technique guide.

Locking Calcaneal Plate

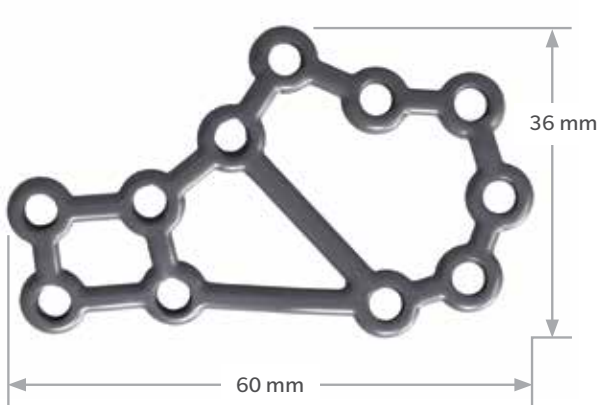

Small

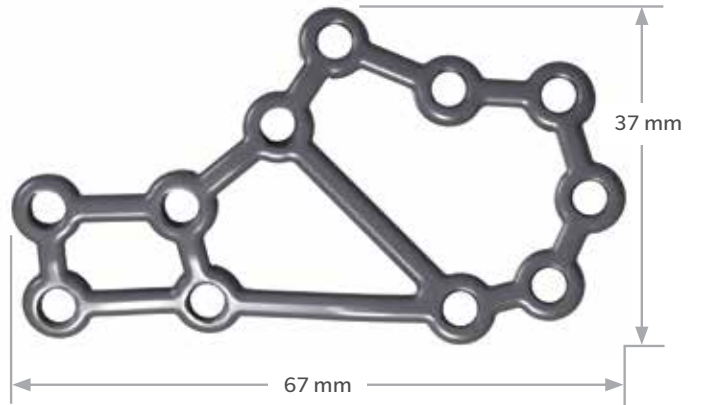



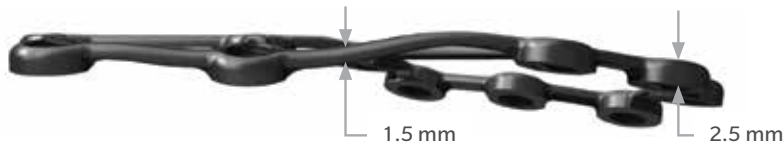
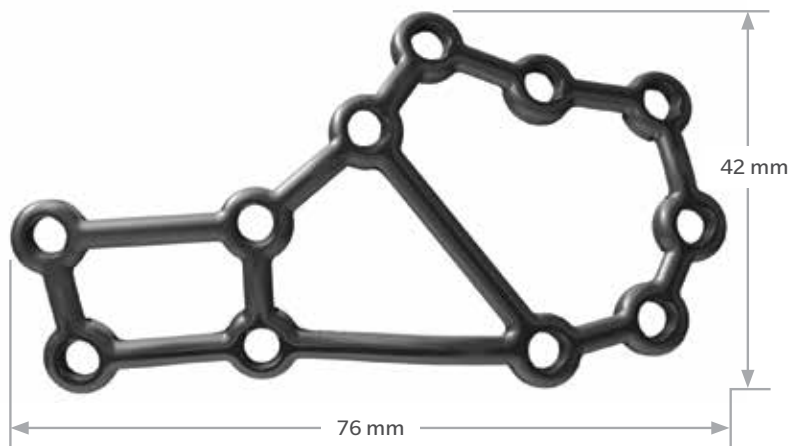





Large



X-Large

Specifications & Screw Options

Screw Type	Diameter Options	Drill Bit	Handle	Driver	Depth Gauge	Length Options
Locking	 3.5 mm (Cat. No. 8161-35-0XX)	2.7 mm Calibrated Drill Bit (Cat. No. 2142-27-070)	Torque Limiting (Cat. No. 2141-18-001)	 T-15 tapered (Cat. No. 2142-15-070)	Small Frag (LOCK line) (Cat. No. 2142-35-100)	10 – 50 mm
	 4.0 mm (Cat. No. 8161-40-0XX)				2.7 mm Drill Meas Sleeve (Cat. No. 8163-01-005)	
	 2.7 mm (Cat. No. 8163-27-0XX)	2.0 mm Marked Drill Bit Short (Cat. No. 2142-88-008)		 T-15 tapered (Cat. No. 2142-15-070)	Small Frag (LOCK line) (Cat. No. 2142-35-100)	2.0 mm Drill Meas Sleeve Short (Cat. No. 2142-88-006)
Non-Locking (Low Profile)	 3.5 mm (Cat. No. 1312-18-0XX)	2.5 mm Drill Bit (Cat. No. 8290-29-070)	Ratcheting Handle (Cat. No. 8261-66-000)	 2.2 mm Square (Cat. No. 8163-01-000)	Small Frag (NON-L line) (Cat. No. 2142-35-100)	14 – 50 mm
(MDS) Multi- Directional	 3.5 mm (Cat. No. 8163-35-0XX)	2.7 mm Calibrated Drill Bit (Cat. No. 2142-27-070)	Ratcheting Handle (Cat. No. 8261-66-000)	 2.2 mm Square (Cat. No. 8163-01-000)	Small Frag (LOCK line) (Cat. No. 2142-35-100)	20 – 50 mm



These are images of models with bones shown with plates in place and not real patients. They are provided to show positioning and not intended to suggest immediate weight bearing.

Navicular Fracture Plate Technique

The A.L.P.S. Navicular Fracture Plates (NFP) are made of a titanium alloy (Ti6Al4V) with a TiMAX treatment for increased fatigue strength compared to the standard alloy.¹ The low-profile anatomic design (1.65 mm thickness) and uniform plate screw construct minimize potential irritation of the ligaments and soft tissue. The Navicular Fracture Plate has been precontoured to closely match the natural anatomy of the navicular bone. In addition to the specific anatomic design, strategic regions of the plate permit the user to intra-operatively contour the plate to match variations in individual patient anatomy. Proprietary F.A.S.T. Guide technology provides a number of unique features that increase flexibility and efficiency in the OR. The plate offers numerous screw options including: 2.5 mm Cortical Locking, 2.5 mm Cortical Non-Locking, and 2.5 mm Multi-Directional Locking Screws.

Navicular Fracture Plate

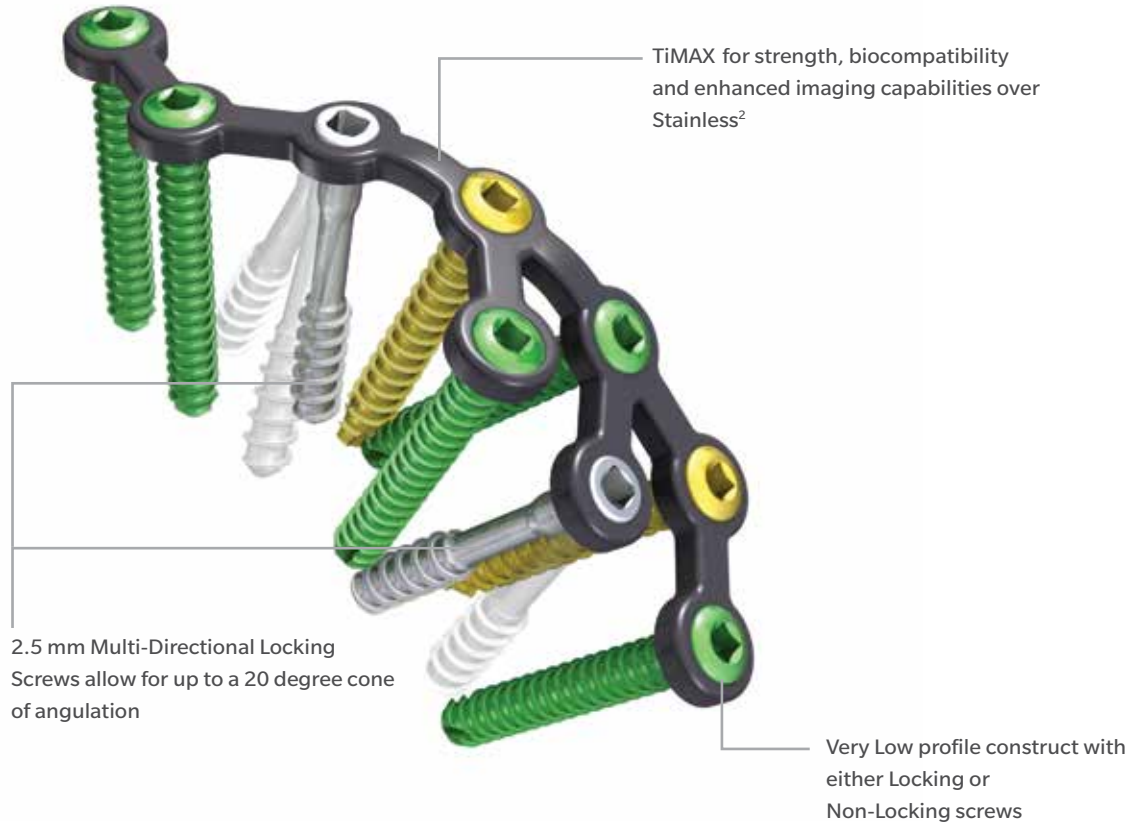

Achieve temporary fixation with the 1.6 mm K-wire inserted directly through any of the available F.A.S.T. Guides

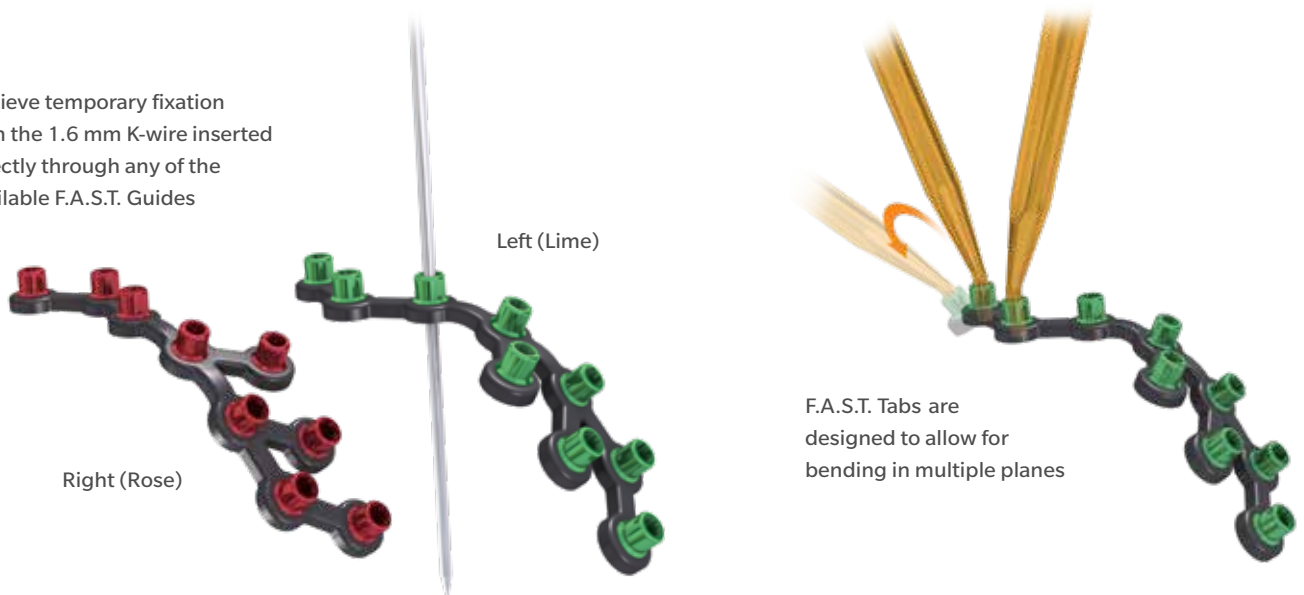

Approach, Reduction and Plate Placement



Figure 1

Step 1: Approach

Make a dorsal longitudinal incision from the midneck of the talus towards the base of the second metatarsal. It may be necessary to make a second longitudinal incision medially from the midneck of the talus to the middle portion of the medial cuneiform. Additionally, it may be necessary to open the talo-navicular and naviculo-cuneiform joint capsule to allow visualization of the joint.

Step 2: Reduction and Plate Placement

After adequate exposure and irrigation of hematoma, the fracture should be reduced and provisionally stabilized with K-wires and/or Reduction Clamps. The plate should be positioned such that the widest portion of the plate is medial (Figure 1).

⊖ **Note:** The plate is designed to fit the navicular bone with the majority of screw fixation extending from medial to lateral.

Provisional Fixation



Figure 2

Step 3: Provisional Fixation

Achieve temporary fixation with the 1.6 mm K-wire (Cat. No. 144256) inserted directly through any of the available F.A.S.T. Guides (Figure 2).

In Situ Contouring

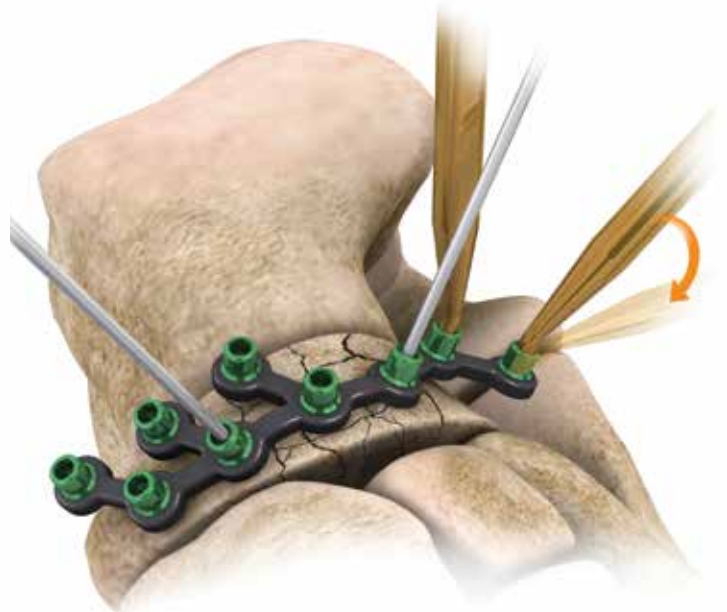

Figure 3

Step 4: Implant Contouring

With the plate provisionally reduced and or partially fixated to bone, it is possible to further contour the plate with the 2.0 mm Plate Bender (Cat. No. 2312-20-100) and 2.0 mm Plate Bender End (Cat. No. 2312-20-101) (Figure 3).

Note: Based on the plate geometry, the majority of contouring will most likely be on the dorsal aspect of the bone.

Suggestion: Depending on the fracture pattern and exposure, it may be necessary to pre-contour the plate prior to insertion. More importantly, minimal exposure will require the user to remove some F.A.S.T. Guides prior to inserting the plate, therefore pre contouring is recommended.

Screw Insertion

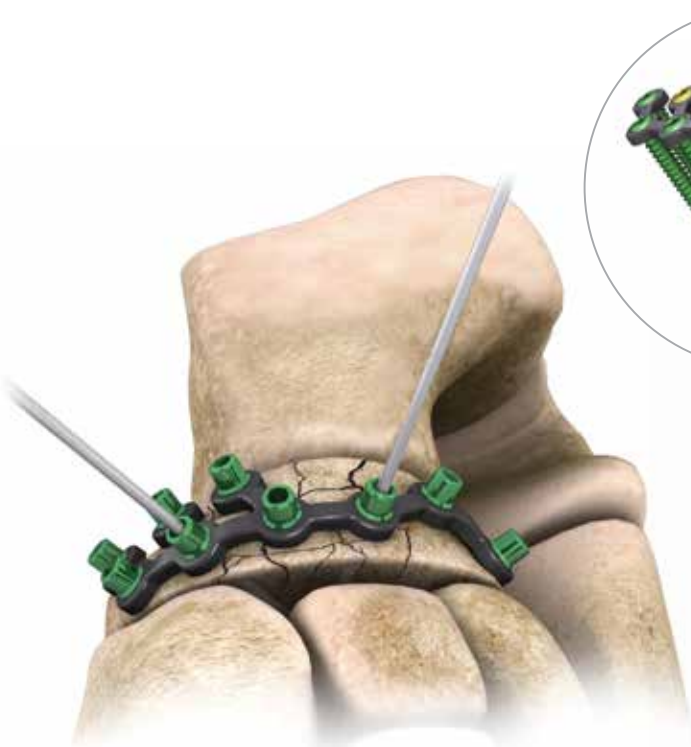

Figure 4



Figure 5

ⓘ **Note:** The Navicular Fracture Bending Templates (Cat. No. 2142-72-001) can be useful in determining plate to bone contouring prior to inserting the plate onto the bone.

Caution: Each bend should be in one direction only; reverse or over bending may weaken or cause plate to break.

Provisionally fix the plate to bone directly through the F.A.S.T. Guides (Figure 4).

Step 5: Reduction and Plate Placement

Each locking hole provides the option for either a Locked Fixed Angle, Locked Multi-Directional, or Non-Locking Screw. Screws can then be placed as needed to secure the fracture (Figure 5).

If a combination of Non-Locking Screws and Locking Screws will be used, Non-Locking Screws should be inserted first.





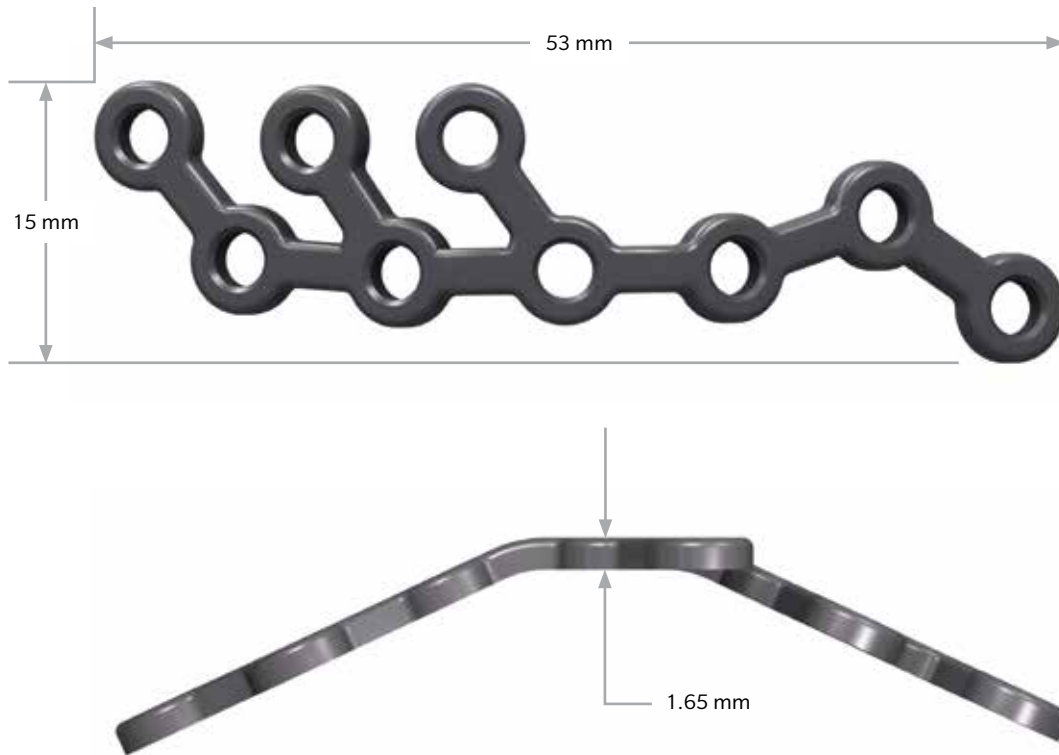

Suggestion: Completely reduce the plate to the bone with three Non-Locking Screws placed sequentially within the dorsal third, middle third and medial third of the plate prior to placing Locking Screws for final fixation.

Additional Locking Screws can then be placed as needed to secure the fracture.

Navicular Fracture Plate



Specifications & Screw Options

Screw Type	Screws	Drill Bit	Handle	Driver	Depth Gauge	Length Options
Locking	 2.5 mm (Cat. No. FPXX)	Drill Bit Fast 2.0 mm (Cat. No. FDB20)	Quick Connect Handle (Cat. No. QCH)	 1.3 mm Square (Cat. No. 2312-18-012)	2.5 mm Depth Gauge (Cat. No. 2312-20-125)	8 – 40 mm
Non-Locking (Low Profile)	 2.5 mm (Cat. No. SPXX000)	Drill Bit Fast 2.0 mm (Cat. No. FDB20)	Quick Connect Handle (Cat. No. QCH)	 1.3 mm Square (Cat. No. 2312-18-012)	2.5 mm Depth Gauge (Cat. No. 2312-20-125)	8 – 40 mm
(MDTP) Multi-Directional	 2.5 mm (Cat. No. 1312-11-1XX)	Drill Bit Fast 2.0 mm (Cat. No. FDB20)	Quick Connect Handle (Cat. No. QCH)	 MDTP Driver (Cat. No. 2142-88-007)	2.5 mm Depth Gauge (Cat. No. 2312-20-125)	10 – 30 mm



These are images of models with bones shown with plates in place and not real patients.
They are provided to show positioning and not intended to suggest immediate weight bearing.

Talar Fracture Technique

The A.L.P.S. Talar Fracture Plates (TFP) are made of a titanium alloy (Ti6Al4V) with a TiMAX treatment for increased fatigue strength compared to the standard alloy.¹ The low-profile anatomic design (1.65 mm thickness) and uniform plate screw construct permits the placement of screws in an extra-articular location into the posterior part of the talar body and into the talar head. The Talar Fracture Plate has been precontoured to closely match the natural anatomy of the lateral aspect of the talar neck. Proprietary F.A.S.T. Guide technology provides a number of unique features that increase flexibility and efficiency. The plate offers numerous screw options including: 2.5 mm Cortical Locking, 2.5 mm Cortical Non-Locking, and 2.5 mm Multi-Directional Locking screws.

Talar Fracture Plate

Low profile construct with either locking or non-locking screws

Threaded holes accept locking 2.5 mm, as well as 2.5 mm Non-Locking Screws

2.5 mm Multi-Directional Locking Screws allow for up to a 20 degree cone of angulation

TiMAX for strength, biocompatibility and enhanced imaging capabilities over Stainless Steel²



K-wire hole for provisional fixation

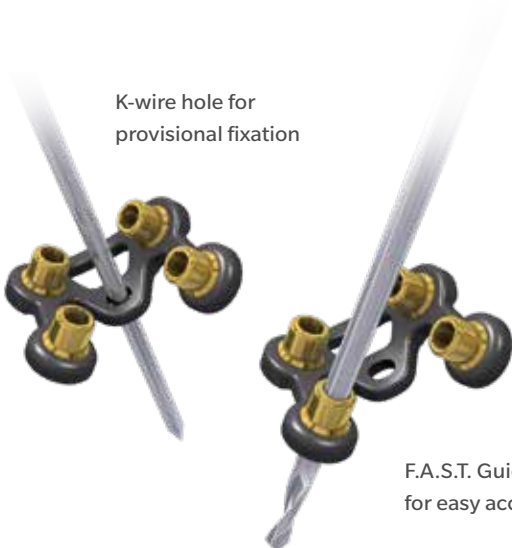

F.A.S.T. Guide inserts for easy accurate drilling

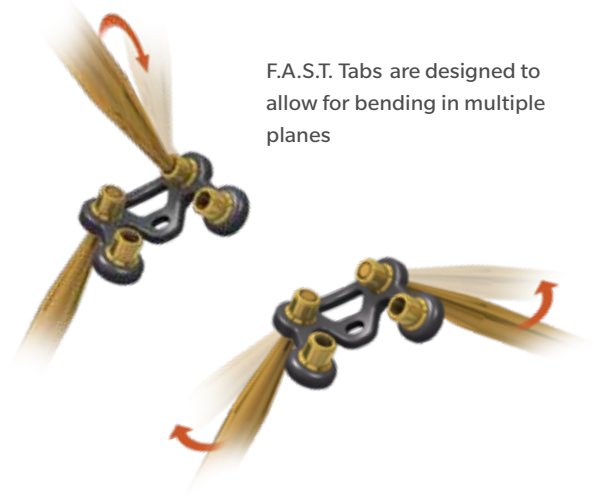

F.A.S.T. Tabs are designed to allow for bending in multiple planes

Approach, Reduction and Plate Placement

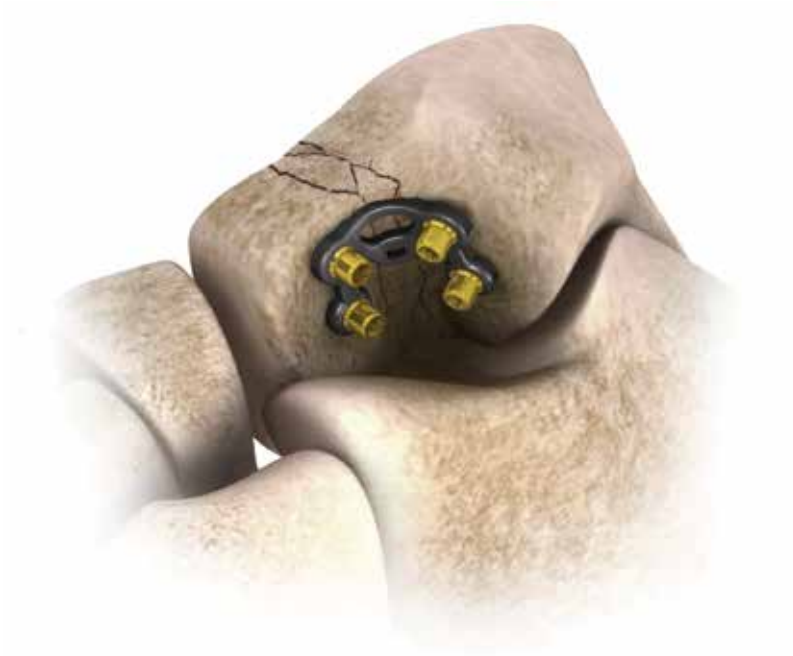

Figure 1

Step 1: Approach

Placement of the Talar Fracture Plate for talar body fractures with displacement, comminution, or an associated talar neck fracture require an anterolateral surgical approach. An anteromedial approach may also be required to obtain additional exposure when addressing medial side comminution. The fractures are reduced, and provisional K-wires placed prior to plate placement.

Step 2: Reduction and Plate Placement

After adequate exposure and irrigation of hematoma, the fracture should be reduced and provisionally stabilized with K-wires. The plate should be positioned laterally within the neck of the talus such that it permits the placement of screws in an extra-articular location into the posterior part of the talar body and into the head of the talus (Figure 1).

Optional Plate Contouring

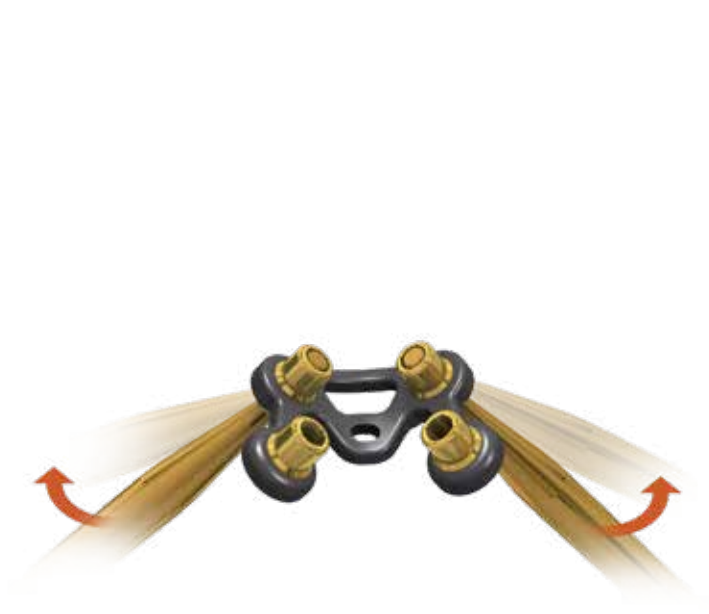

Figure 2



Figure 3

ⓘ **Note:** The Talar Fracture Bending Templates (Cat. No. 2142-75-001) can be useful in determining plate to bone contouring prior to inserting the plate onto the bone.

Figure 2 demonstrates the general positioning of 2.0 mm Bending Irons to reduce the concavity of the plate.

Figure 3 demonstrates the general positioning of 2.0 mm Bending Irons to increase the concavity of the plate.

Provisional Fixation

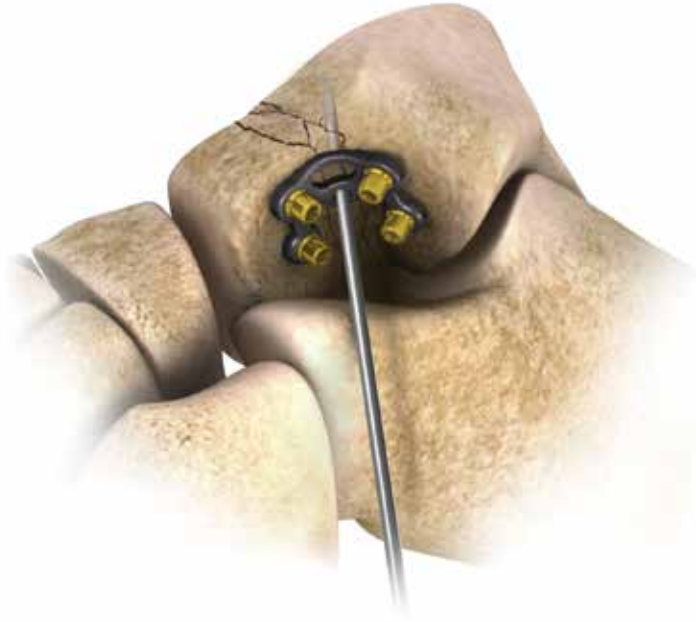

Figure 4

In Situ Contouring

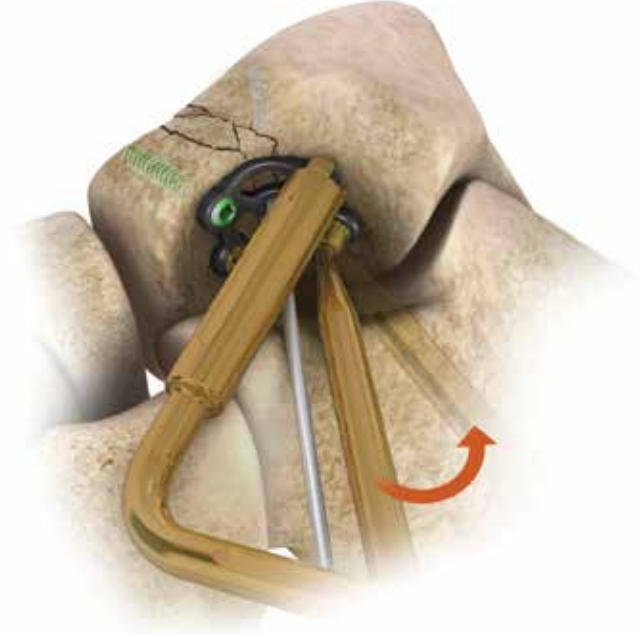

Figure 5

Step 3: Provisionally Fixation

Achieve temporary fixation with a 1.6 mm K-wire (Cat. No. 14425-6), through the K-Wire hole in the plate (Figure 4).

Step 4: In Situ Contouring

With the plate provisionally reduced to the bone, it is possible, although technically challenging due to limited access, to further contour the plate intraoperatively with the 2.0 mm Plate Bender (Cat. No. 2312-20-100) and 2.0 mm Plate Bender End (Cat. No. 2312-20-101) (Figure 5).

Caution Each bend should be in one direction only; reverse or over bending may weaken or cause plate to break.

Suggestion: To preserve the reduction and assist with multi-planar intraoperative contouring the plate should have two points of fixation. Therefore, applying one screw to either side of the most superior aspect of the plate will provide a more stable construct for intraoperative customization and help maintain the reduction.

Screw Fixation

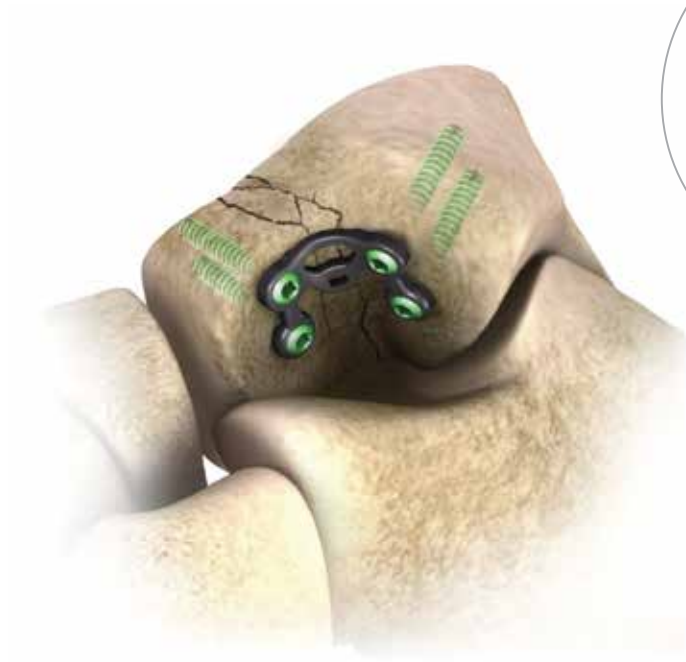

Figure 6

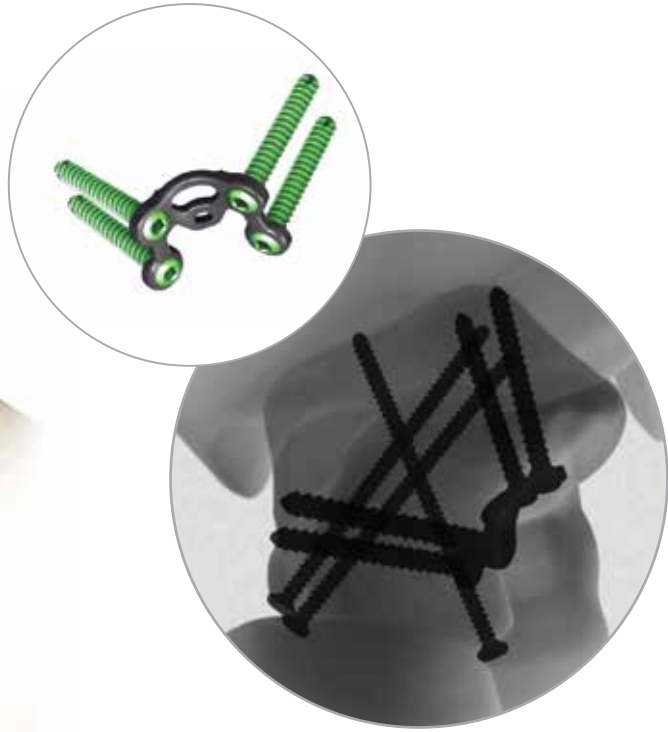

Figure 7

Step 5: Screw Fixation

Insert screws in all screw holes (Figure 6).

Each locking hole provides the option for either a locked fixed angle, Locked Multi-Directional, or Non-Locking Screw.

If a combination of Non-Locking Screws and Locking Screws are used, Non-Locking Screws should be inserted first.







Suggestion Using fluoroscopic x-ray ensures that all screws are correctly placed and are of the correct length (Figure 7).

- ⓘ **Note:** Additional cannulated screws used outside the plate may be required to further stabilize the fracture at the surgeon's discretion (Figure 7).
- ⓘ **Note:** A detailed technique for screw insertion can be found in the screw section of this technique guide.

Talar Fracture Plate



Specifications & Screw Options

Screw Type	Screws	Drill Bit	Handle	Driver	Depth Gauge	Length Options
Locking	 2.5 mm (Cat. No. FPXX)	Drill Bit Fast 2.0 mm (Cat. No. FDB20)	Quick Connect Handle (Cat. No. QCH)	 1.3 mm Square (Cat. No. 2312-18-012)	2.5 mm Depth Gauge (Cat. No. 2312-20-125)	8 – 40 mm
Non-Locking (Low Profile)	 2.5 mm (Cat. No. SPXX000)	Drill Bit Fast 2.0 mm (Cat. No. FDB20)	Quick Connect Handle (Cat. No. QCH)	 1.3 mm Square (Cat. No. 2312-18-012)	2.5 mm Depth Gauge (Cat. No. 2312-20-125)	8 – 40 mm
(MDTP) Multi- Directional	 2.5 mm (Cat. No. 1312-11-1XX)	Drill Bit Fast 2.0 mm (Cat. No. FDB20)	Quick Connect Handle (Cat. No. QCH)	 MDTP Driver (Cat. No. 2142-88-007)	2.5 mm Depth Gauge (Cat. No. 2312-20-125)	10 – 30 mm



Compression Wire Technique: Provisional Fixation

The choice is yours; Biomet's innovative plating technology provide several ways in which to achieve provisional plate fixation to the bone using the A.L.P.S. Total Foot System and other A.L.P.S. platform plating options. Standard K-wires through K-wire holes is an option, as well as K-wires through F.A.S.T. Guides , K-wires through F.A.S.T. Guide Adapters, Fixation Pins, or plate to bone clamps. The use of Compression Wires has an added advantage over standard K-wires in that the plate is compressed to the bone with the bead on the wire, not allowing the plate to rise back up, which is possible with standard K-wires. These Compression Wires can be utilized with the smaller 2.5 mm A.L.P.S. plates, and also the larger 3.5 mm plates in the A.L.P.S. Total Foot System.

Compression Wires

Recommended Length Combinations	2.5 F.A.S.T Guide (2.5 mm Plate)	3.5 F.A.S.T. Guide (3.5 mm Plate)	2.0 F.A.S.T. Guide Adapter (Over 3.5 F.A.S.T. Guide)
SHORT Compression Wire (23 mm)	•		
MEDIUM Compression Wire (28 mm)	•		
LONG Compression Wire (48 mm)		•	•

Table 1

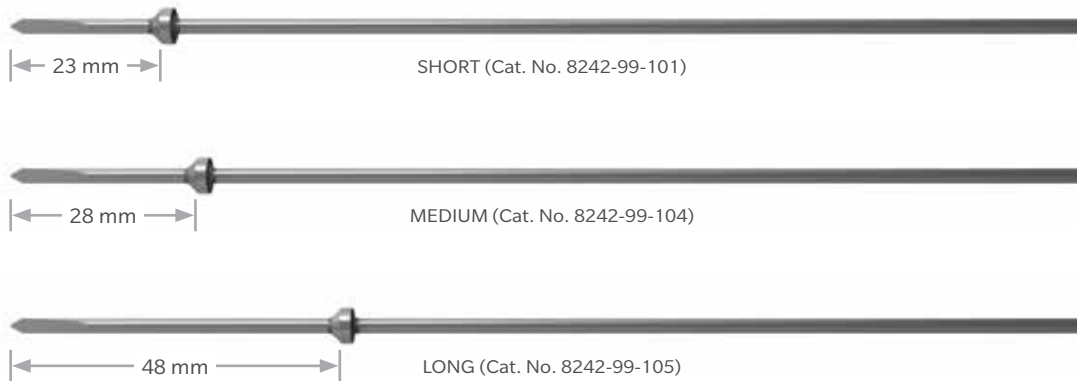

Compression Wires

Compression Wires can be used through F.A.S.T. Guides to provisionally position and hold a plate down on the bone. In addition, the 2.0 mm F.A.S.T. Guide Adapters (Cat. No. 2312-18-007) can also be used to convert 3.5 mm plate F.A.S.T. Guides into provisional fixation holes as necessary.

Recommended Compression Wire lengths and F.A.S.T. Guide combinations ensure that the wires are used with the appropriate guide with adequate functional wire length, and allows for controlled wire positioning with regards to the locked hole (Table 1).

If concentric positioning is not as critical, Compression Wires may be used through F.A.S.T. Guides as well as directly through the locked holes, and length may be chosen according to bone geometry.



Figure 1: Short



Figure 2: Medium



Figure 3: Long

Provisional Fixation

2.5 mm Plate

Once the position of a 2.5 mm plate has been established over the bone/joint, a Short Compression Wire (Cat. No. 8242-99-101) can be drilled directly through the F.A.S.T. Guide until the distal side of the bead on the wire bottoms out on the F.A.S.T. Guide, and the plate is held down to the bone as shown in (Figure 1). A Medium Compression Wire (Cat. No. 8242-99-104) can also be utilized if a longer K-wire is preferred (Figure 2).

Provisional Fixation

3.5 mm Plate

When a 3.5 mm plate has been selected and the position established over the bone/joint, a Long Compression Wire (Cat. No. 8242-99-105) can be drilled through the 3.5 mm F.A.S.T. Guide, or through a 2.0 mm F.A.S.T. Guide Adapter inserted into a F.A.S.T. Guide to hold the plate down to the bone (Figure 3).

Compression wires may also be utilized with other A.L.P.S. platform plates that have K-wire holes in the plate.

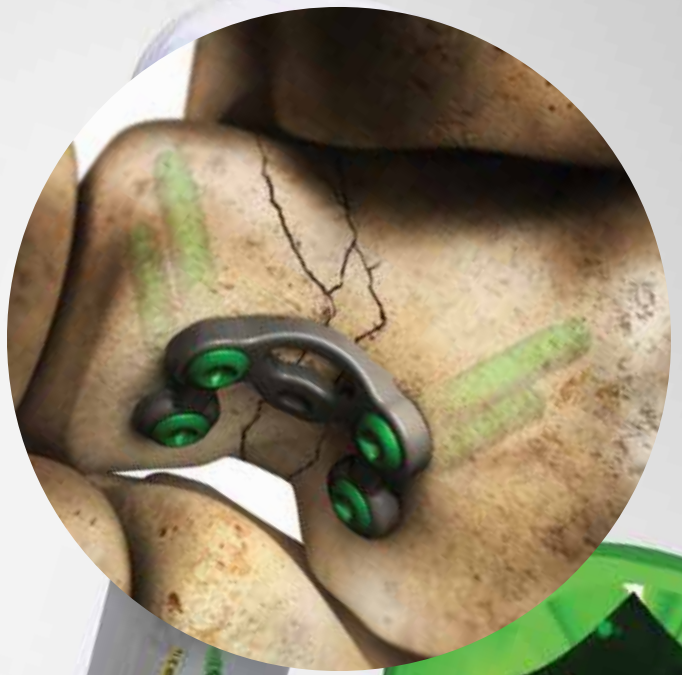

Screw Options and Insertion Techniques

The choice is yours; Biomet's innovative locked plating technology offers the surgeon a comprehensive array of low profile screw options. Choose locking, non-locking, or multi-directional locking screws according to need and without compromising plate profile. Each threaded hole gives the surgeon an option of placing a non-locking screw within a locking hole.

Screw Options



2.5 mm Locking Screw: (Cat. No. FPXX)

- Larger core diameter and shallower thread pitch for improved bending and shear strength compared to a standard 2.5 mm Cortical Screw
- Self tapping tip minimizes the need for pre-tapping and eases screw insertion
- Locking Screw head minimizes screw back-out and construct pullout
- When paired with the 2.5 mm Compression Washer, it can be used as a compression screw in the 2.5 mm plate compression holes
- Square drive
- Available in lengths of 8 – 40 mm

⊖ **Note:** In order to prevent protrusion from the far cortex, the Screw Peg 2.5mm and Fully-Threaded Peg 2.5mm already have a 2mm offset in length.



2.5 mm Non-Locking Screw: (Cat. No. SPXX000)

- Self tapping tip minimizes the need for pre-tapping and eases screw insertion
- Square drive
- Available in lengths of 8 – 40 mm

⊖ **Note:** In order to prevent protrusion from the far cortex, the Screw Peg 2.5mm and Fully-Threaded Peg 2.5mm already have a 2mm offset in length.



2.5 mm Multi-Directional Threaded Peg: (Cat. No. 1312111XX)

- CoCr Screws create new thread path in the plate
- Multi-Directional capability offers a 20 degree cone of angulation
- Locking Screw head minimizes screw back-out and construct pullout
- Square drive
- Available in lengths of 10 – 30 mm



2.5 mm Compression Washer: (Cat. No. 1312-20-025)

- Convert only the 2.5 mm Locking Cortical Screw into a compression screw
- Designed to be used in the compression holes in the 2.5 mm plates
- Compression Washer is ONLY meant for use with the 2.5 mm Locking Cortical Screw

2.5 mm Locking/Non-Locking Screw Insertion



2.5 mm Cortical Locking Screw
(Cat. No. FPXX)



2.5 mm Non-Locking Screw
(Cat. No. SPXX000)



Figure 1



Figure 2

Step 1: Drill

Center the F.A.S.T. 2.0 mm Drill Bit w/ Mini-Quick Connect (Cat. No. 2312-20-204) into the F.A.S.T. Guide, drill to desired length (Figure 1).

Note: Plate compression to the bone must be achieved prior to the insertion of any locking screws. Compression can be achieved by the use of 2.5 mm Non-Locking Screws. Also, the plate benders can be used with the F.A.S.T. Guide to anatomically reduce the plate to the bone in-situ.

Caution Do not begin drilling until the drill bit is perpendicular to and touches the bone. Inserting the drill bit into the F.A.S.T. Guide while the drill is on may cause damage to the drill bit or F.A.S.T. Guide.

Step 2: Remove F.A.S.T. Guide

Using the 1.3 mm Square Screwdriver (Cat. No. 2312-18-012) coupled to the Mini-Quick Connect Handle (Cat. No. MQC) to remove the F.A.S.T. Guide (Figure 2).

2.5 mm Locking Screw Insertion



Figure 3

Step 3: Measure

Using the 2.0 mm/2.5 mm Bone Depth Gauge (Cat. No. 2312-20-125) measure screw length by taking a reading from the NON-FG. line of the depth gauge (Figure 3).

⊖ Note: If the F.A.S.T. Guide is not removed before gauging the screw depth, use the FG scale on the Depth Gauge.

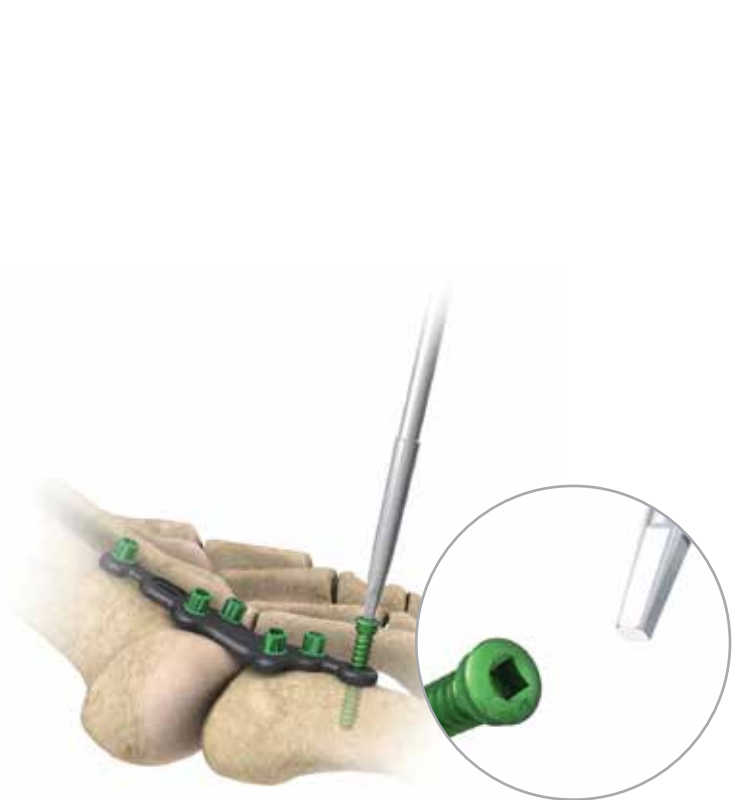

Figure 4

Step 4: Insertion

Insert the appropriate length Locking or Non-Locking Screw with the 1.3 mm Square Screwdriver (Cat. No. 2312-18-012) and Mini-Quick Connect Handle (Cat. No. MQC) (Figure 4).

2.5 mm Multi-Directional Locking Screw Insertion



**2.5 mm Multi-Directional Locking Screw
(Cat. No. 1312111XX)**

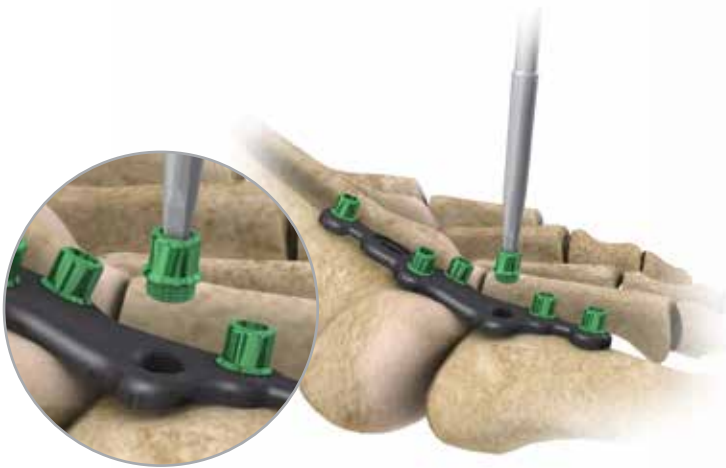

Figure 5



Figure 6

Step 1: Remove F.A.S.T. Guide

Using the 2.5 mm MDTP Driver (Cat. No. 2142-88-007) coupled to the Mini-Quick Connect Handle (Cat. No. MQC) remove the F.A.S.T. Guide (Figure 5).

Step 2: Drill

Using the 2.7/2.0 mm Double Drill Guide (Cat. No. 9399-99-435) and the F.A.S.T. 2.0 mm Drill Bit w/Mini-Quick Connect (Cat. No. 2312-20-204) drill off-axis at an angle no greater than 10 degrees off center (20 degree cone) (Figure 6).

2.5 mm Multi-Directional Locking Screw Insertion



Figure 7

Step 3: Measure

Insert the appropriate length Locking or Non-Locking Screw with the 1.3 mm Square Screwdriver (Cat. No. 2312-18-012) and Mini-Quick Connect Handle (Cat. No. MQC) (Figure 4).

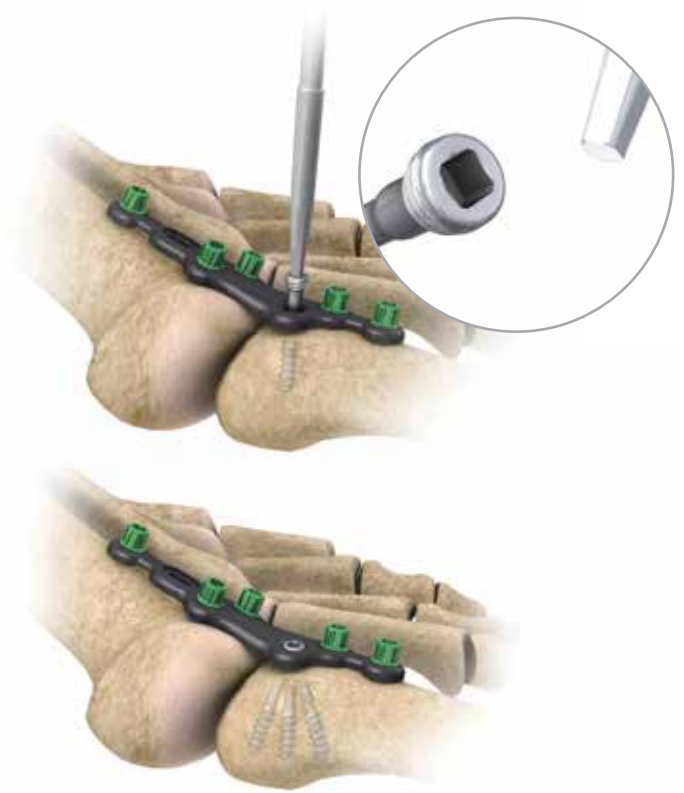

Figure 8

Step 4: Insert Locking Screw

Insert the locking screw with the MDTP driver (Cat. No. 2142-88-007) and MQC Driver (Cat. No. MQC) (Figure 8).

- ⓘ Note: It is possible, with enough force, to drive the 2.5 mm MDTPs through the plate. Stop inserting when the head of the screw is flush with the surface of the plate.
- ⓘ Note: Using a power screwdriver is not recommended for insertion of any locking screw. If using power, it should be at a slow speed, with the Torque-Limiting Adapter. Perform all final screw tightening by hand.



Small Fragment Screw Options and Insertion Techniques

The choice is yours; Zimmer Biomet's innovative locked plating technology offers the surgeon a comprehensive array of low profile screw options. Choose locking, non-locking, or multi-directional locking screws according to need and without compromising plate profile. With the added feature of the low profile non-locking screw, each tapered threaded hole gives the surgeon an option of placing a non-locking screw within a locking hole.

Small Frag Screw Options



2.7 mm Locking Cortical Screw: (Cat. No. 8163-27-0XX)

- Low profile head design reduces prominence beyond the plate
- Self tapping tip eases screw insertion
- Tapered screw head and triple lead thread helps ensure alignment of the screw head into the plate hole
- Tapered threaded head minimizes screw back-out and construct pullout
- T-15 drive
- Available in lengths of 10 – 50 mm
- Screw uses a 2.0 mm Marked Drill Bit Short (Cat. No. 2142-88-008)



3.5 mm Locking Cortical Screw: (Cat. No. 8161-35-0XX)

- Larger core diameter and shallower thread pitch for improved bending and shear strength compared to a standard 3.5 mm Cortical Screw
- Self tapping tip minimizes the need for pre-tapping and eases screw insertion
- Tapered screw head and triple lead thread helps ensure alignment of the screw head into the plate hole
- Tapered threaded head minimizes screw back-out and construct pullout
- T-15 drive
- Available in lengths of 10 – 50 mm
- Screw uses a 2.7 mm Drill Bit (Cat. No. 2141-27-070)



4.0 mm Locking Cancellous Screw: (Cat. No. 8161-40-0XX)

- Larger thread diameter and an aggressive thread pitch for improved pull-out strength compared to the 3.5 mm Locking Cortical Screw, for revision and rescue operations.
- Self tapping tip minimizes the need for pre-tapping and eases screw insertion
- Tapered screw head and triple lead thread helps ensure alignment of the screw head into the plate hole
- Tapered threaded head minimizes screw back-out and construct pullout
- T-15 drive
- Available in lengths of 10 – 50 mm
- Screw uses a 2.7 mm Drill Bit (Cat. No. 2141-27-070)

Screw Options



3.5 mm Locking Multi-Directional Screw: (Cat. No. 8163-35-0XX)

- Cobalt-Chrome screw with large core diameter
- Multi-Directional capability offers a 30 degree cone of angulation
- Creates own thread in plate to help provide strong and stable construct
- Self tapping tip minimizes the need for pre-tapping and eases screw insertion
- 2.2 mm Square Drive
- Available in lengths of 10 – 50 mm
- Screw uses the 2.7 mm Drill Bit (Cat. No. 2142-27-070)



3.5 mm Low Profile Non-Locking Screw: (Cat. No. 1312-18-0XX)

- Low profile head design reduces prominence beyond the plate
- Self tapping tip eases screw insertion
- Square drive for maximum torque delivery
- Type 2 anodized material for increased fatigue strength compared to 316 stainless steel and standard Ti alloy
- Available Low Profile Washer converts screw head to traditional Non-Locking Screw head (for use when the surgeon decides to use the screw on its own) (Cat. No. 1312-18-000)
- Screw uses a 2.5 mm Drill Bit (Cat. No. 8290-29-070) and can be installed in any of the plates threaded holes
- Available in lengths of 10 – 50 mm



3.5 mm Low Profile Cortical Washer: (Cat. No. 1312-18-000)

- Convert only the 3.5 mm Low Profile Non-locking Screw into a compression screw
- Compression Washer is ONLY meant for use with the 3.5 mm Non-Locking Cortical Screw

2.7 mm Locking Screw Insertion



2.7 mm Cortical Locking Screw
(Cat. No. 8163-27-0XX)

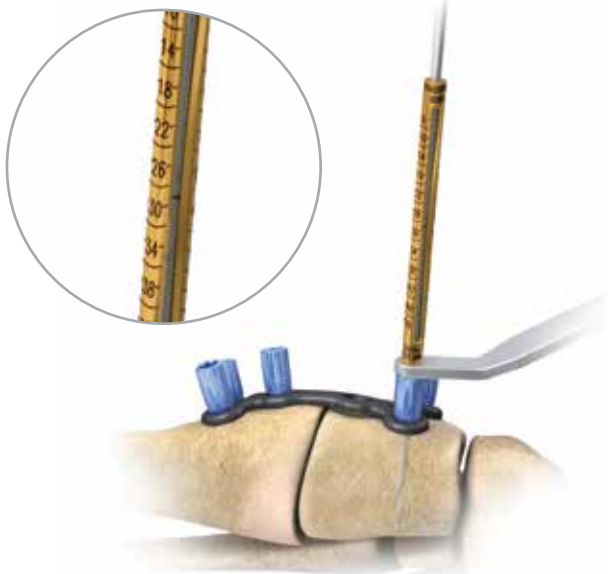

Figure 1



Figure 2

ⓘ Note: Plate compression to the bone must be achieved prior to the insertion of any locking screws. Compression can be achieved by the use of Reduction Forceps, Bone Clamp, Provisional Fixation Pins or 3.5 mm Low Profile Non-Locking Screws. Also, the plate benders can be used with the F.A.S.T. Guide to anatomically reduce the plate to the bone in-situ.

Step 1a: Drill and measure

Before drilling place the 2.0 Adapter Drill Sleeve (Cat. No. 2142-88-006) into the F.A.S.T. Guide. Next, insert the 2.0 mm Marked Drill Bit Short (Cat. No. 2142-88-008) into the F.A.S.T. Guide and slide 2.0 Adapter Drill Sleeve Short (Cat. No. 2142-88-006) completely on top of the F.A.S.T. Guide. Now drill to the desired depth, remove the drill while leaving the Measuring Sleeve in place and use the scale on the 2.0 Adapter Drill Sleeve Short to identify the appropriate length screw (Figure 1).

Do not begin drilling until the Drill Bit touches the bone. Inserting the drill bit into the F.A.S.T. Guide while the drill is on may cause damage to the Drill Bit or F.A.S.T. Guide.

Step 1b: Measure alternative

Alternatively, the Small Frag Depth Gauge (Cat. No. 2142-35-100) may be used to measure screw length after the F.A.S.T. Guide is removed with the T-15 Driver by taking a direct reading from the LOCK line from the Small Frag Depth Gauge.

Step 2: Remove F.A.S.T. Guide

Remove the F.A.S.T. Guide using the T-15 Driver (Cat. No. 2142-15-070) (Figure 2).



Figure 3

Step 3: Insertion

Insert the Locking Screw with the T-15 Taper Driver (Cat. No. 2142-15-070) coupled with the Torque-Limiting Screw Driver Handle (Cat. No. 2141-18-001) (Figure 3).



Figure 4

Step 4: Alternative Insertion

Alternatively, the screw may be inserted under power using the T-15 Taper Driver (Cat. No. 2142-15-070) coupled to the Torque Limiting Power Adapter (Cat. No. 2312-18-020) (Figure 4).

ⓘ Note: Using a power screwdriver is not recommended for insertion of any locking screw. If using power, it should be at a slow speed, with the Torque-Limiting Adapter. Perform all final screw tightening by hand.

3.5 mm & optional 4.0 mm Locking Screw Insertion



3.5 mm Cortical Locking Screw
(Cat. No. 8161-35-0XX)



4.0 mm Cancellous Locking Screw*
(Cat. No. 8161-40-0XX)

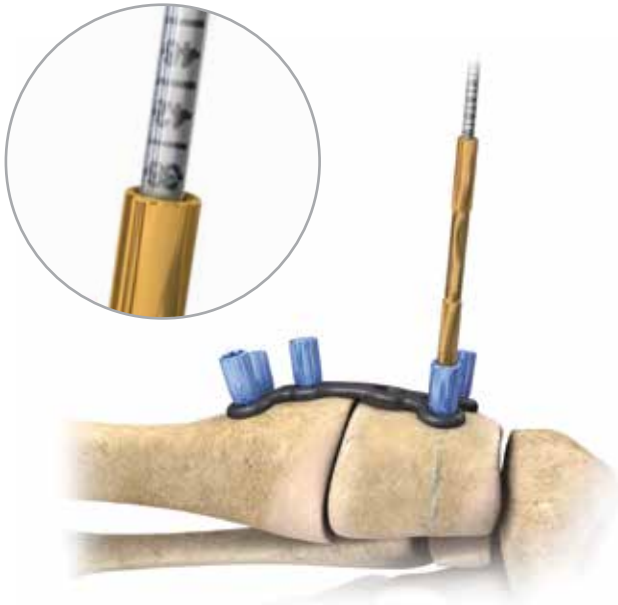

Figure 5



Figure 6

Note: Plate compression to the bone must be achieved prior to the insertion of any Locking Screws. Compression can be achieved by the use of Provisional Fixation Pins (Cat. No. 8242-99-001) or 3.5 mm Low Profile Non-Locking Screws. Also, the plate benders can be used with the F.A.S.T. Guide to anatomically reduce the plate to the bone in-situ.

Step 1a: Drill and Measure

Before drilling insert the 2.7 mm Calibrated Drill Bit (Cat. No. 2142-27-070) into the F.A.S.T. Guide and slide the Drill Measuring Sleeve (Cat. No. 8163-01-005) completely on top of the F.A.S.T. Guide. Next, drill to the desired depth, remove the drill while leaving the Measuring Sleeve in place and use the scale on the calibrated drill bit to identify the appropriate length screw (Figure 5).

Caution: Do not begin drilling until the Drill Bit touches the bone. Inserting the drill bit into the F.A.S.T. Guide while the drill is on may cause damage to the Drill Bit or F.A.S.T. Guide.

Step 1b: Measure alternative

Alternatively, the Small Frag Depth Gauge may be used to measure screw length after the F.A.S.T. Guide is removed with the T-15 Driver by taking a direct reading from the LOCK line from the Small Frag Depth Gauge (Cat. No. 2142-35-100).

Step 2: Remove F.A.S.T. Guide

Remove the F.A.S.T. Guide using the T-15 Driver (Cat. No. 2142-15-070) (Figure 6).



Figure 7

Step 3: Insertion

Insert the Locking Screw with the T-15 Taper Driver (Cat. No. 2142-15-070) coupled with the Torque-Limiting Screwdriver Handle (Cat. No. 2141-18-001) (Figure 7).



Figure 8

Step 4: Alternative Insertion

Alternatively, the screw may be inserted under power using the T-15 Taper Driver (Cat. No. 2142-15-070) coupled to the Torque Limiting Power Adapter (Cat. No. 2312-18-020) (Figure 8).

3.5 mm Multi-Directional Locking Screw Insertion



Figure 9

Step 1: Remove F.A.S.T. Guide

Remove the F.A.S.T. Guide using the T-15 Driver (Cat. No. 2142-15-070) (Figure 9).



3.5 mm Multi-Directional Locking Screw (MDS)
(Cat. No. 8163-35-0XX)

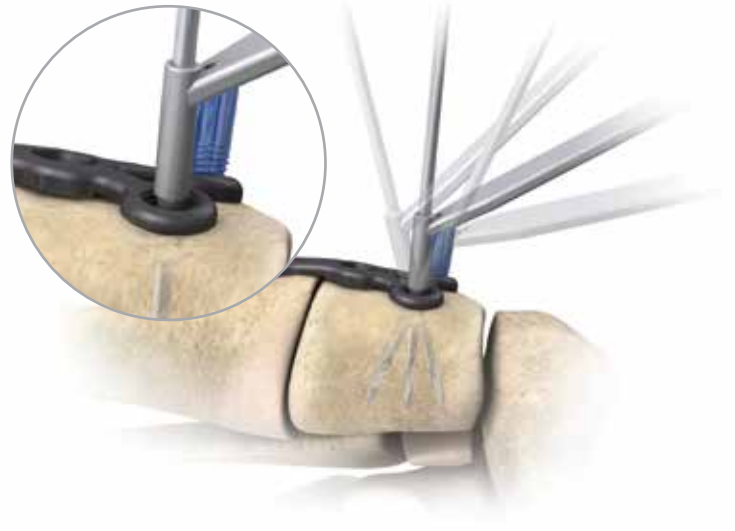

Figure 10

Step 2: Drill

Choose the trajectory of the screw using the 2.7 mm end of the 2.0/2.7 mm Drill Guide (Cat. No. 9399-99-435) and drill to the desired depth with up to 15 degrees of angulation from center (30 degree cone) through a threaded locking hole (Figure 10).



Figure 11

Step 3: Measure

Choose the appropriate the Multi-Directional Screw (Cat. No. 8163-35-0XX) length with the Small Frag Depth Gauge (Cat. No. 2142-35-100) by taking a direct reading from the LOCK line (locked line) reading of the Small Frag Depth Gauge (Figure 11).



Figure 12

Step 4: Alternative Insertion

Insert the screw using T-15 driver (Cat. No. 8163-01-000) coupled to the Ratchet Handle (Cat. No. 8261-66-000) (Figure 12).

ⓘ Note: It is important not to use the Torque-Limiting Driver handle because it does not generate the necessary torque required to fully seat the MDS Screw into the threaded locking hole.

3.5 mm Multi-Directional Locking Screw Insertion

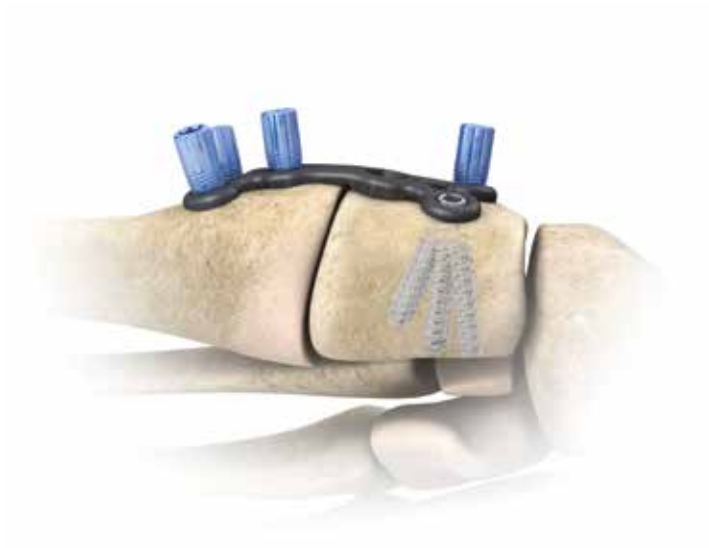

Figure 13

Step 4: Insertion (cont.)

Multi-Directional Locking Screws (MDS) allows up to 15 degrees of angulation from center (Figure 13).

3.5 mm Non-Locking Low Profile Screw Insertion



Figure 14

Step 1: Remove F.A.S.T. Guide

If non-locking screws are to be used through a locking hole, the F.A.S.T. Guide is removed using the T-15 Driver (Cat. No. 2142-15-070) (Figure 14).



3.5 mm Cortical Low Profile Non-Locking Screw
(Cat. No.1312-18-0XX)

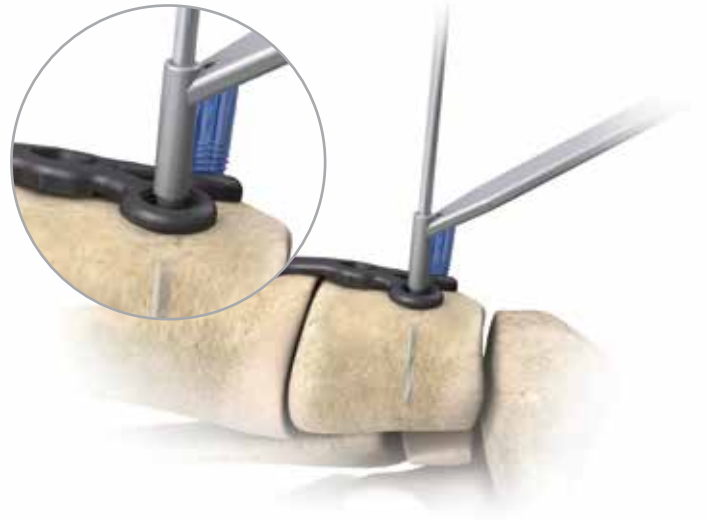

Figure 15

Step 2a: Threaded Hole Insertion

Place the 2.5 mm end of the 2.5/3.5 mm Drill Sleeve (Cat. No. 8241-96-000) within the threaded hole and drill through both cortices with the 2.5 mm Drill Bit (Cat. No. 8290-29-070) (Figure 15).

3.5 mm Non-Locking Low Profile Screw Insertion

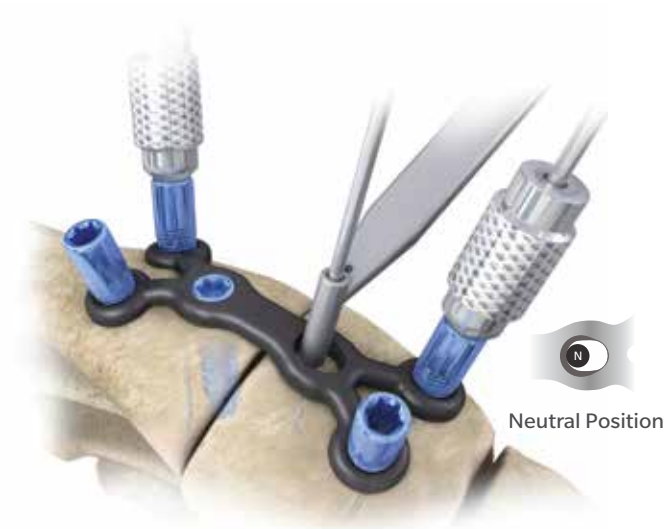

Figure 16



Figure 17

The compression slots of the A.L.P.S. Foot system are unidirectional and provide as much as 1.25 mm of compression per slot if drilled eccentrically. The direction of compression can be identified by observing the asymmetric nature of the compression slot.

Step 2b: Compression Hole Insertion; Neutral insertion of Non-Locking Screw

Place the 2.5 mm end of the 2.5/3.5 mm Drill Sleeve (Cat. No. 8241-96-000) within the widest portion of the unidirectional compression slot and drill to the desired depth with the 2.5 mm Drill Bit (Cat. No. 8290-29-070) (Figure 16).

Step 2c: Compression Hole Insertion; Eccentric Insertion/ Dynamic Compression of Non-Locking Screw

With the adjacent bone segment rigidly fixed to the plate with a screw, place the 2.5 mm end of the 2.5/3.5 mm Drill Guide (Cat. No. 8241-96-000) eccentrically in the narrowest portion of the unidirectional slot and drill through both cortices using the 2.5 mm Drill Bit (Cat. No. 8290-29-070) (Figure 17).



Figure 18

Step 3: Measure

Identify the appropriate screw length using the Small Frag Depth Gauge (Cat. No. 2142-35-100) by taking a direct reading from the NON-L (Non-Locked) line (Figure 18).



Figure 19

Step 4: Insert

Insert the appropriate length 3.5 mm Low-Profile Non-Locking Cortical Screw using the 2.2 mm Square Driver (Cat. No. 8163-01-000) and Ratchet Handle (Cat. No. 8261-66-000) (Figure 19).

A.L.P.S. Foot 2.7– 3.5 Module

Instrumentation

Part Number	Description
8299-60-030	A.L.P.S.Foot 2.7– 3.5 Module
2312-18-010	2.0 mm FG Converter Handle
9399-99-435	Double Drill Guide 2.7/2.0 mm
8241-96-000	Double Drill Guide 2.5/3.5
2142-15-070	T-15 Tapered Driver
8163-01-000	2.2 mm Square Driver
2142-35-100	Small Frag Depth Gauge



Disposables

Part Number	Description
8290-32-070	Drill Twist Scp 3.5 X 70 mm
2142-88-008	Marked Drill Bit Short 2.0 mm
2142-27-070	2.7 mm Calib Drill Bit
8290-29-070	Drill Bit 2.5 mm
2142-88-006	2.0 mm Drill Measuring Sleeve Short
8163-01-005	2.7 mm Measuring Drill Sleeve

Implants

Product	Part Number	Description
 <p>2.7 mm Cortical Locking Screws</p>	8163-27-010	2.7 mm Cortical Locking Screw 10 mm
	8163-27-012	2.7 mm Cortical Locking Screw 12 mm
	8163-27-014	2.7 mm Cortical Locking Screw 14 mm
	8163-27-016	2.7 mm Cortical Locking Screw 16 mm
	8163-27-018	2.7 mm Cortical Locking Screw 18 mm
	8163-27-020	2.7 mm Cortical Locking Screw 20 mm
	8163-27-022	2.7 mm Cortical Locking Screw 22 mm
	8163-27-024	2.7 mm Cortical Locking Screw 24 mm
	8163-27-026	2.7 mm Cortical Locking Screw 26 mm
	8163-27-028	2.7 mm Cortical Locking Screw 28 mm
	8163-27-030	2.7 mm Cortical Locking Screw 30 mm
	8163-27-032	2.7 mm Cortical Locking Screw 32 mm
	8163-27-034	2.7 mm Cortical Locking Screw 34 mm
	8163-27-036	2.7 mm Cortical Locking Screw 36 mm
	8163-27-038	2.7 mm Cortical Locking Screw 38 mm
	8163-27-040	2.7 mm Cortical Locking Screw 40 mm
	8163-27-042	2.7 mm Cortical Locking Screw 42 mm
	8163-27-044	2.7 mm Cortical Locking Screw 44 mm
8163-27-046	2.7 mm Cortical Locking Screw 46 mm	
8163-27-048	2.7 mm Cortical Locking Screw 48 mm	
8163-27-050	2.7 mm Cortical Locking Screw 50 mm	

Implants

Product	Part Number	Description
 <p data-bbox="264 842 427 898">3.5 mm Cortical Locking Screws</p>	8161-35-010	3.5 mm Cortical Locking Screw 10 mm
	8161-35-012	3.5 mm Cortical Locking Screw 12 mm
	8161-35-014	3.5 mm Cortical Locking Screw 14 mm
	8161-35-016	3.5 mm Cortical Locking Screw 16 mm
	8161-35-018	3.5 mm Cortical Locking Screw 18 mm
	8161-35-020	3.5 mm Cortical Locking Screw 20 mm
	8161-35-022	3.5 mm Cortical Locking Screw 22 mm
	8161-35-024	3.5 mm Cortical Locking Screw 24 mm
	8161-35-026	3.5 mm Cortical Locking Screw 26 mm
	8161-35-028	3.5 mm Cortical Locking Screw 28 mm
	8161-35-030	3.5 mm Cortical Locking Screw 30 mm
	8161-35-032	3.5 mm Cortical Locking Screw 32 mm
	8161-35-034	3.5 mm Cortical Locking Screw 34 mm
	8161-35-036	3.5 mm Cortical Locking Screw 36 mm
	8161-35-038	3.5 mm Cortical Locking Screw 38 mm
	8161-35-040	3.5 mm Cortical Locking Screw 40 mm
	8161-35-042	3.5 mm Cortical Locking Screw 42 mm
	8161-35-044	3.5 mm Cortical Locking Screw 44 mm
	8161-35-046	3.5 mm Cortical Locking Screw 46 mm
	8161-35-048	3.5 mm Cortical Locking Screw 48 mm
8161-35-050	3.5 mm Cortical Locking Screw 50 mm	
 <p data-bbox="220 1654 469 1711">3.5 mm CoCr Multi Directional Screws</p>	8163-35-020	3.5 mm Multi Directional Locking Screw 20 mm
	8163-35-022	3.5 mm Multi Directional Locking Screw 22 mm
	8163-35-024	3.5 mm Multi Directional Locking Screw 24 mm
	8163-35-026	3.5 mm Multi Directional Locking Screw 26 mm
	8163-35-028	3.5 mm Multi Directional Locking Screw 28 mm
	8163-35-030	3.5 mm Multi Directional Locking Screw 30 mm
	8163-35-032	3.5 mm Multi Directional Locking Screw 32 mm
	8163-35-034	3.5 mm Multi Directional Locking Screw 34 mm
	8163-35-036	3.5 mm Multi Directional Locking Screw 36 mm
	8163-35-038	3.5 mm Multi Directional Locking Screw 38 mm
	8163-35-040	3.5 mm Multi Directional Locking Screw 40 mm
	8163-35-042	3.5 mm Multi Directional Locking Screw 42 mm
	8163-35-044	3.5 mm Multi Directional Locking Screw 44 mm
	8163-35-046	3.5 mm Multi Directional Locking Screw 46 mm
	8163-35-048	3.5 mm Multi Directional Locking Screw 48 mm
8163-35-050	3.5 mm Multi Directional Locking Screw 50 mm	

A.L.P.S. Foot 2.7– 3.5 Module

Implants

Product	Part Number	Description
 <p>3.5 mm Low Profile Non-Locking Cortical Screws</p>	1312-18-014	3.5 mm Low Profile Cortical 14 mm
	1312-18-016	3.5 mm Low Profile Cortical 16 mm
	1312-18-018	3.5 mm Low Profile Cortical 18 mm
	1312-18-020	3.5 mm Low Profile Cortical 20 mm
	1312-18-022	3.5 mm Low Profile Cortical 22 mm
	1312-18-024	3.5 mm Low Profile Cortical 24 mm
	1312-18-026	3.5 mm Low Profile Cortical 26 mm
	1312-18-028	3.5 mm Low Profile Cortical 28 mm
	1312-18-030	3.5 mm Low Profile Cortical 30 mm
	1312-18-032	3.5 mm Low Profile Cortical 32 mm
	1312-18-034	3.5 mm Low Profile Cortical 34 mm
	1312-18-036	3.5 mm Low Profile Cortical 36 mm
	1312-18-038	3.5 mm Low Profile Cortical 38 mm
	1312-18-040	3.5 mm Low Profile Cortical 40 mm
	1312-18-042	3.5 mm Low Profile Cortical 42 mm
	1312-18-044	3.5 mm Low Profile Cortical 44 mm
	1312-18-046	3.5 mm Low Profile Cortical 46 mm
1312-18-048	3.5 mm Low Profile Cortical 48 mm	
1312-18-050	3.5 mm Low Profile Cortical 50 mm	
	1312-18-000	3.5 mm Low Profile Cortical Washer

A.L.P.S. Foot 2.5 Module

Instrumentation

Part Number	Description
8299-60-040	A.L.P.S. Foot 2.5 Module
2312-20-101	2.5 End Bender
2312-20-100	2.5 Bender
2312-20-110	2.5 Plate Holder
QCH	Handle Quick Connect
2312-18-014	2.5 mm Counterbore
2312-20-125	2.5 mm Bone Depth Gage
2142-88-007	MDTP Driver
2312-18-012	1.3 mm Square Screwdriver
2142-75-001	Template Talar Neck
2142-72-001	Template Navicular

Disposables

Part Number	Description
FDB20	Drill Bit Fast 2.0 mm



Implants

Product	Part Number	Description
Low Profile Cortical Washer	1312-20-025	2.5 mm Threaded Washer
1 st MTP Fusion	8240-71-001	1 st MTP Fusion Left
	8240-71-101	1 st MTP Fusion Right
Talar Neck Plate	8240-75-001	Talar Neck Plate
Navicular Plate	8240-72-001	Navicular Plate Left
	8240-72-101	Navicular Plate Right
Metatarsal Fracture Plates*	1312-20-251	2.5 mm Locking Plate, Straight
	1312-20-255	2.5 mm Locking Plate, Web

* For stabilization and fixation of small bone fragments in fresh fracture, revision procedures, joint fusion and reconstruction of small bones of the hand, foot, wrist, humerus, scapula, finger, toe, pelvis and craniomaxillofacial skeleton, particularly in osteopenic bone.

A.L.P.S. Foot 2.5 Module

Implants

Product	Part Number	Description
 <p>2.5 mm FP Locking Screw</p>	FP08	Peg Full Thread 2.5 X 8 mm
	FP10	Peg Full Thread 2.5 X 10 mm
	FP12	Peg Full Thread 2.5 X 12 mm
	FP14	Peg Full Thread 2.5 X 14 mm
	FP16	Peg Full Thread 2.5 X 16 mm
	FP18	Peg Full Thread 2.5 X 18 mm
	FP20	Peg Full Thread 2.5 X 20 mm
	FP22	Peg Full Thread 2.5 X 22 mm
	FP24	Peg Full Thread 2.5 X 24 mm
	FP26	Peg Full Thread 2.5 X 26 mm
	FP28	Peg Full Thread 2.5 X 28 mm
	FP30	Peg Full Thread 2.5 X 30 mm
	FP32	Peg Full Thread 2.5 X 32 mm
	FP34	Peg Full Thread 2.5 X 34 mm
	FP36	Peg Full Thread 2.5 X 36 mm
	FP38	Peg Full Thread 2.5 X 38 mm
	FP40	Peg Full Thread 2.5 X 40 mm
	1312-20-025	2.5 mm Compression Washer
 <p>2.5 mm Multi Directional Threaded Peg</p>	1312-11-110	Multi Directional Threaded Peg 2.5 X 10 mm
	1312-11-112	Multi Directional Threaded Peg 2.5 X 12 mm
	1312-11-114	Multi Directional Threaded Peg 2.5 X 14 mm
	1312-11-116	Multi Directional Threaded Peg 2.5 X 16 mm
	1312-11-118	Multi Directional Threaded Peg 2.5 X 18 mm
	1312-11-120	Multi Directional Threaded Peg 2.5 X 20 mm
	1312-11-122	Multi Directional Threaded Peg 2.5 X 22 mm
	1312-11-124	Multi Directional Threaded Peg 2.5 X 24 mm
	1312-11-126	Multi Directional Threaded Peg 2.5 X 26 mm
	1312-11-128	Multi Directional Threaded Peg 2.5 X 28 mm
1312-11-130	Multi Directional Threaded Peg 2.5 X 30 mm	

Implants

Product	Part Number	Description
 <p data-bbox="240 793 451 856">2.5 mm SP Non-Locking Screws</p>	SP08000	Peg Screw 2.5 X 8 mm
	SP10000	Peg Screw 2.5 X 10 mm
	SP12000	Peg Screw 2.5 X 12 mm
	SP14000	Peg Screw 2.5 X 14 mm
	SP16000	Peg Screw 2.5 X 16 mm
	SP18000	Peg Screw 2.5 X 18 mm
	SP20000	Peg Screw 2.5 X 20 mm
	SP22000	Peg Screw 2.5 X 22 mm
	SP24000	Peg Screw 2.5 X 24 mm
	SP26000	Peg Screw 2.5 X 26 mm
	SP28000	Peg Screw 2.5 X 28 mm
	SP30000	Peg Screw 2.5 X 30 mm
	SP32000	Peg Screw 2.5 X 32 mm
	SP34000	Peg Screw 2.5 X 34 mm
	SP36000	Peg Screw 2.5 X 36 mm
	SP38000	Peg Screw 2.5 X 38 mm
SP40000	Peg Screw 2.5 X 40 mm	

A.L.P.S. Foot 3.5 Plates and Instruments Module

Instrumentation

Part Number	Description
8299-60-020	A.L.P.S. Foot 3.5 Plates and Instruments
2142-88-003	Compression Distraction Device
2142-88-004	Foot Multi-Planar Bender
2142-88-005	Double F.A.S.T. Guide Benders
2312-18-007	2.0 mm F.A.S.T. Guide Adapter
2142-08-001	Template Locking Calc Sm
2142-08-003	Template Locking Calc Lg
2142-74-001	Template Midfoot Fusion Sm
2142-74-003	Template Midfoot Fusion Lg

Part Number	Description
2142-77-020	Template Compression Fusion
2142-76-101	Template Medial Clmn Fusion
2142-77-021	Template Closed Fusion Sm
2142-77-022	Template Closed Fusion Lg

Disposables

Part Number	Description
14425-6	1.6 mm X 6In K-Wire
141796.	2.0 mm X 6In K-Wire
2142-88-009	4.5 mm Canc Self-Drill Pin Ao

Implants

Product	Part Number	Description
Single Joint Fusion Plate	8240-77-020	Compression Fusion Plate
	8240-77-021	Closed Fusion Plate Small
	8240-77-022	Closed Fusion Plate Large
Lateral Column Lengthening Plate	8240-73-000	No Wedge
	8240-73-001	Small Wedge
	8240-73-002	Medium Wedge
	8240-73-003	Large Wedge
Midfoot Fusion Plate	8240-74-001	Midfoot Fusion Plate Small
	8240-74-003	Midfoot Fusion Plate Large
Medial Column Fusion Plate	8240-76-001	Medial Column Fusion Plate Left
	8240-76-101	Medial Column Fusion Plate Right
Locking Calcaneus Plate	8162-08-001	Locking Calcaneus Plate Small Left
	8162-08-003	Locking Calcaneus Plate Large Left
	8162-08-004	Locking Calcaneus Plate XL Left
	8162-09-001	Locking Calcaneus Plate Small Right
	8162-09-003	Locking Calcaneus Plate Large Right
	8162-09-004	Locking Calcaneus Plate XL Right

A.L.P.S. Foot Instruments Tray

Product	Part Number	Description
Foot Instrument Tray	8299-60-002	A.L.P.S. Foot Instrument Tray
	2312-18-020	Trq Lmt Pwr Adpt Ao 2Nm
	8261-66-000	Ratchet Screwdriver Handle Sm
	2141-18-001	Sm Torque Limiting Driver
	2312-18-021	T-15 Tapered Driver Short
	2142-88-003	Distraction/Compression Device

A.L.P.S. Foot Line Extension Components

Instrumentation

Part Number	Description
010000363	Cup Reamer 14 mm
010000364	Cup Reamer 16 mm
010000365	Cup Reamer 18 mm
010000366	Cup Reamer 20 mm
010000367	Cup Reamer 22 mm
110010566	Cup Reamer 24 mm
010000368	Cone Reamer 14 mm
010000369	Cone Reamer 16 mm
010000370	Cone Reamer 18 mm
010000371	Cone Reamer 20 mm
010000372	Cone Reamer 22 mm
110010565	Cone Reamer 24 mm
2312-18-007	2.0 mm F.A.S.T. Guide Adapter
2312-20-212	1 st MTP Fusion Plate Bender

Disposables

Part Number	Description
8242-99-101	2.0 mm Compression Wire Short
8242-99-104	2.0 mm Compression Wire Medium
8242-99-105	2.0 mm Compression Wire Long
14425-6	K-Wire 1.6 mm x 6 In Bayonet

Cases and Trays

Part Number	Description
8299-60-003	A.L.P.S. Foot Extension Lid
8299-60-004	A.L.P.S. Foot Extension Base
8299-60-005	A.L.P.S. Foot Extension Case
8299-60-006	A.L.P.S. Cup and Cone Reamer Case
8299-60-007	A.L.P.S. Cup and Cone Reamer Base
8299-60-008	Cup and Cone Reamer Lid

Implants

Part Number	Description
8240-76-002	Lapidus Plate
8240-71-001	1 st MTP Fusion Plate Left
8240-71-101	1 st MTP Fusion Plate Right
8240-71-002	1 st MTP Fusion Plate Large Left
8240-71-102	1 st MTP Fusion Plate Large Right
8240-77-023	Small 2.5 mm In-Line Fusion Plate
8240-77-024	Large 3.5 mm In-Line Fusion Plate

References

1. Compared to 316L Electropolished Stainless Steel, Type I Anodized titanium, and machined titanium. Citation: Data on file at Biomet. Test # DVA-107504-DVER. Mechanical testing is not necessarily indicative of clinical performance.
2. TiMAX Material Brochure. "TiMAX Offers Advanced Benefits for Reliable Fracture Fixation". 2001, DePuy ACE.

This material is intended for health care professionals.

Please refer to the Instructions for Use and the package label for the products to be used with this Surgical Technique. For indications, contraindications, warnings, precautions, potential adverse effects and patient counseling information, see the package insert or contact your local representative; visit www.zimmerbiomet.com for additional product information. Check for country product clearances and reference product specific instructions for use.

Zimmer Biomet does not practice medicine. This technique was developed in conjunction with health care professionals. Each surgeon should exercise his or her own independent judgment in the diagnosis and treatment of an individual patient, and this information does not purport to replace the comprehensive training surgeons have received. As with all surgical procedures, the technique used in each case will depend on the surgeon's medical judgment as the best treatment for each patient. Results will vary based on health, weight, activity, and other variables. Not all patients are candidates for this product and/or procedure. Caution: Federal (USA) law restricts this device to sale by or on the order of a surgeon. Rx only.

©2014, 2021, 2023, 2024 Zimmer Biomet



3699.3-GLBL-en-Issue Date-2024-06
VV-12213



Legal Manufacturer

Biomet Trauma
P.O. Box 587
56 E. Bell Drive
Warsaw, Indiana 46581-0587
USA

www.zimmerbiomet.com

CE2797

CE mark on a surgical technique is not valid unless there is a CE mark on the product label.