



A.L.P.S.™ Hand
Fracture System

Surgical Technique



Table of Contents

A.L.P.S. Hand Fracture System.....	3
F.A.S.T. Guide Inserts & Multi-Directional Screws.....	5
Locking, Non-Locking, & Multi-Directional Screw Options	7
Surgeon Design Team.....	8
Introduction	9
1.5 mm Locking Plates.....	10
1.5 mm Plate Specifications	11
2.5 mm Locking Plates.....	12
2.5 mm Plate Specifications	13
Plate Options.....	14
Instruments.....	16
Surgical Technique	18
Multi-Directional Screw Insertion.....	24
Ordering Information	25

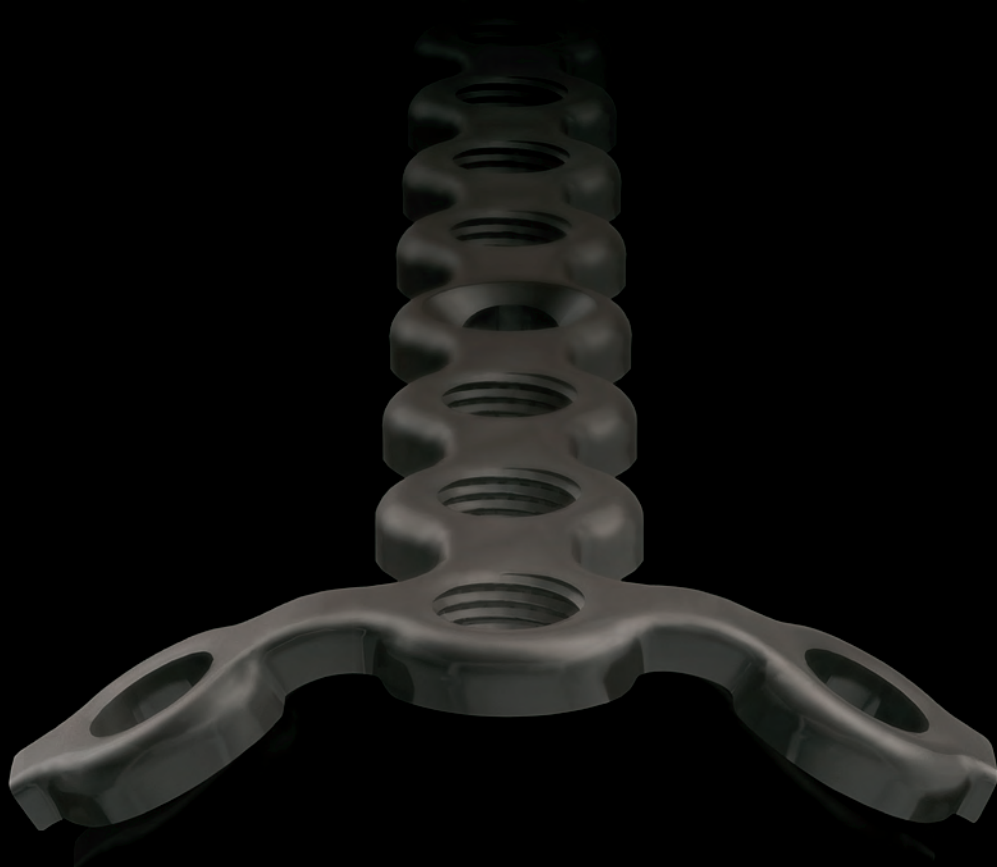

Low Profile, Locked Plating, Anatomically Contoured

A.L.P.S. Hand Fracture System

- Low profile plates are designed to help minimize discomfort and soft tissue irritation
- Contoured plates mimic the anatomy of the fingers
- Plates are available in six plate styles, to suit fracture complexity
- Flexible Plating Technology delivers in-situ contourability
- Cobalt chrome screws for strong stable fixation

For metacarpal and phalangeal procedures that often involve complex fractures and minimal tissue coverage, the Hand Fracture System provides both strength and low-profile advantages. Having one of the thinnest profiles available and contourable to align with the fingers, these plates may be used to treat even the most challenging cases.

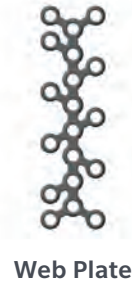

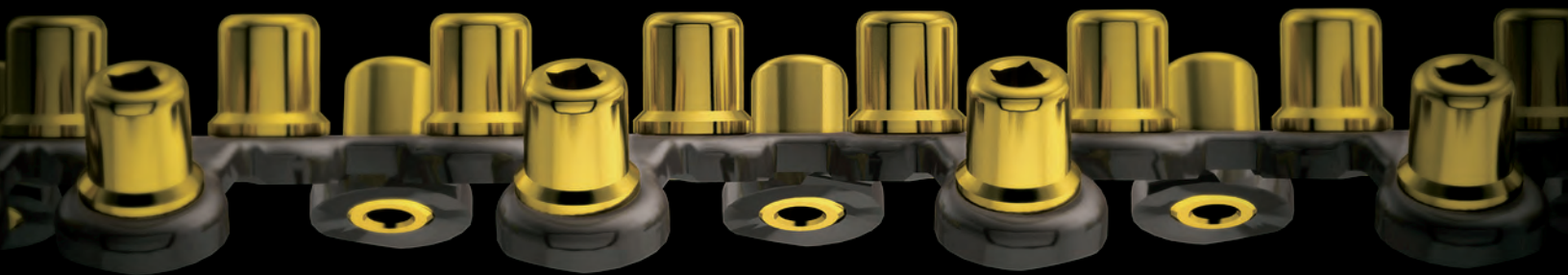
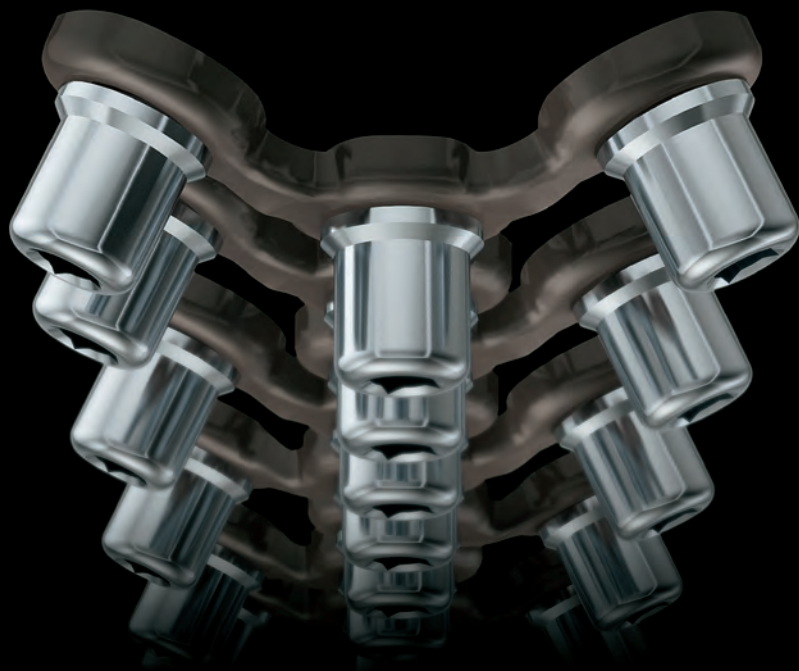

F.A.S.T. Guide® Inserts, Multi-Directional Screws

F.A.S.T. Guide Inserts

- Facilitate accurate drilling
- Pre-loaded and disposable
- Save time in the O.R.:
No intraoperative assembly is required
- Color coded F.A.S.T. Guide® inserts
make identification easy:
Silver = 1.5 mm, Gold = 2.5 mm

To facilitate surgical procedures even further, the Hand Fracture System Plates come pre-loaded with Fixed Angle Screw Targeting F.A.S.T. Guide inserts.

Multi-Directional Screws

- Cobalt Chrome screws create a strong mechanical lock
- 1.5 mm and 2.5 mm screws provide angular stability in a locked construct

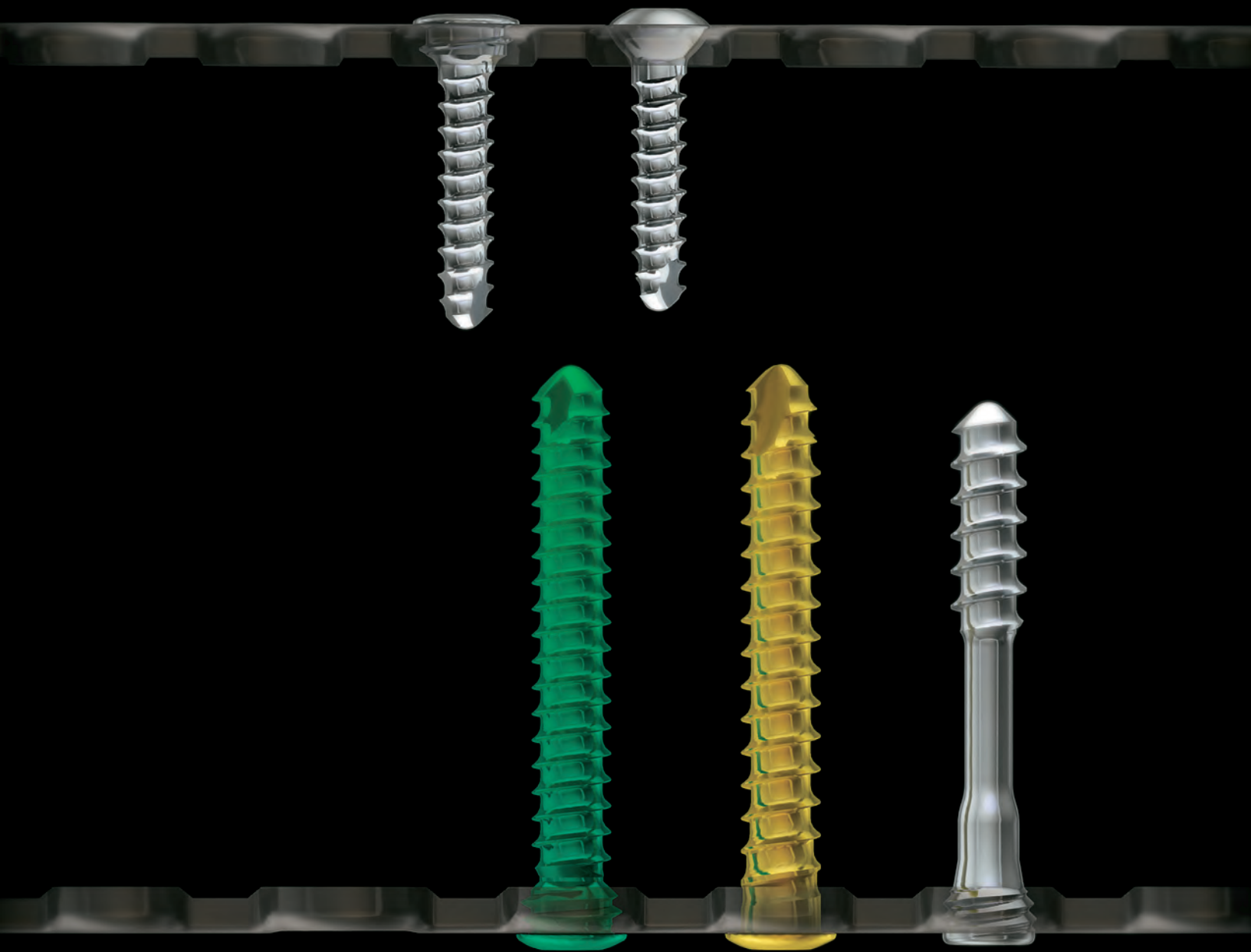

Versatility in Construct

Locking, Non-Locking and Multi-Directional Screw Options

- Choose locking, non-locking, or multi-directional screws according to need
- All options available in each locking hole
- Locking screws establish a fixed angle construct for strong fixation or when optimal screw purchase is required
- Locking Multi-Directional Screws allow for angulation from fixed angle axis
- 1.5 mm Non-locking and 2.5 mm locking screws with washers can be utilized with slotted holes to create axial compression at the fracture site

Particularly helpful in challenging fracture cases, the multiple screw options allow plates and screws to be placed as close to the bone surface as possible.

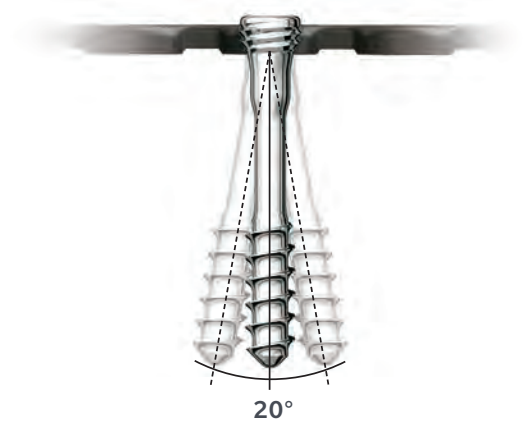



Surgeon Design Team

Lloyd P. Champagne, M.D.
Arizona Center for Hand Surgery
Phoenix, Arizona

Brian J. Hartigan, M.D. (Deceased)
Northwestern School of Medicine
Chicago, Illinois

Matthew M. Tomaino, M.D., M.B.A.
Tomaino Orthopaedic Care
Rochester, New York

Introduction

The A.L.P.S. Hand Fracture System represents the next generation in anatomic plate design. It combines the benefits of low profile titanium plate metallurgy with the advantages of multiplanar locked screw technology. These features allow the formation of a three dimensional matrix of fixed and variable angle screws to create a true subchondral scaffold that can provide fixation in comminuted fractures or in osteoporotic bone.

The A.L.P.S. Hand Fracture System features TiMAX® low profile, anatomically contoured implants. In hand surgery where soft tissue coverage is at risk, these low profile plates are designed to minimize discomfort and soft tissue irritation matching the anatomy of the phalanx and metacarpal, while still maintaining adequate strength.

The System features F.A.S.T. Guide inserts and Flexible Plating Technology to facilitate surgical procedures and save time in the operating room. F.A.S.T. Guide inserts allow for accurate drilling and placement of screws. F.A.S.T. Guide inserts are preloaded and do not require intraoperative assembly, designed to save time in the OR.

Additionally, the A.L.P.S. Hand Fracture System allows the use of locking, variable angle, and standard screws. This hybrid fixation concept allows the surgeon to stabilize the fracture either by the use of lag screw techniques through the plate, or by compression plating techniques. Locking screws serve to provide stability to comminuted, unstable metaphyseal fractures or in osteopenic bone.

Intended Use:

This system is intended for stabilization and fixation of small bone fragments in fresh fractures, revision procedures, joint fusion and reconstructions of small bones of the hand, foot, wrist, ankle, humerus, scapula, finger, toe, pelvis and craniomaxillofacial skeleton, particularly in osteopenic bone.

1.5 mm Locking Plates

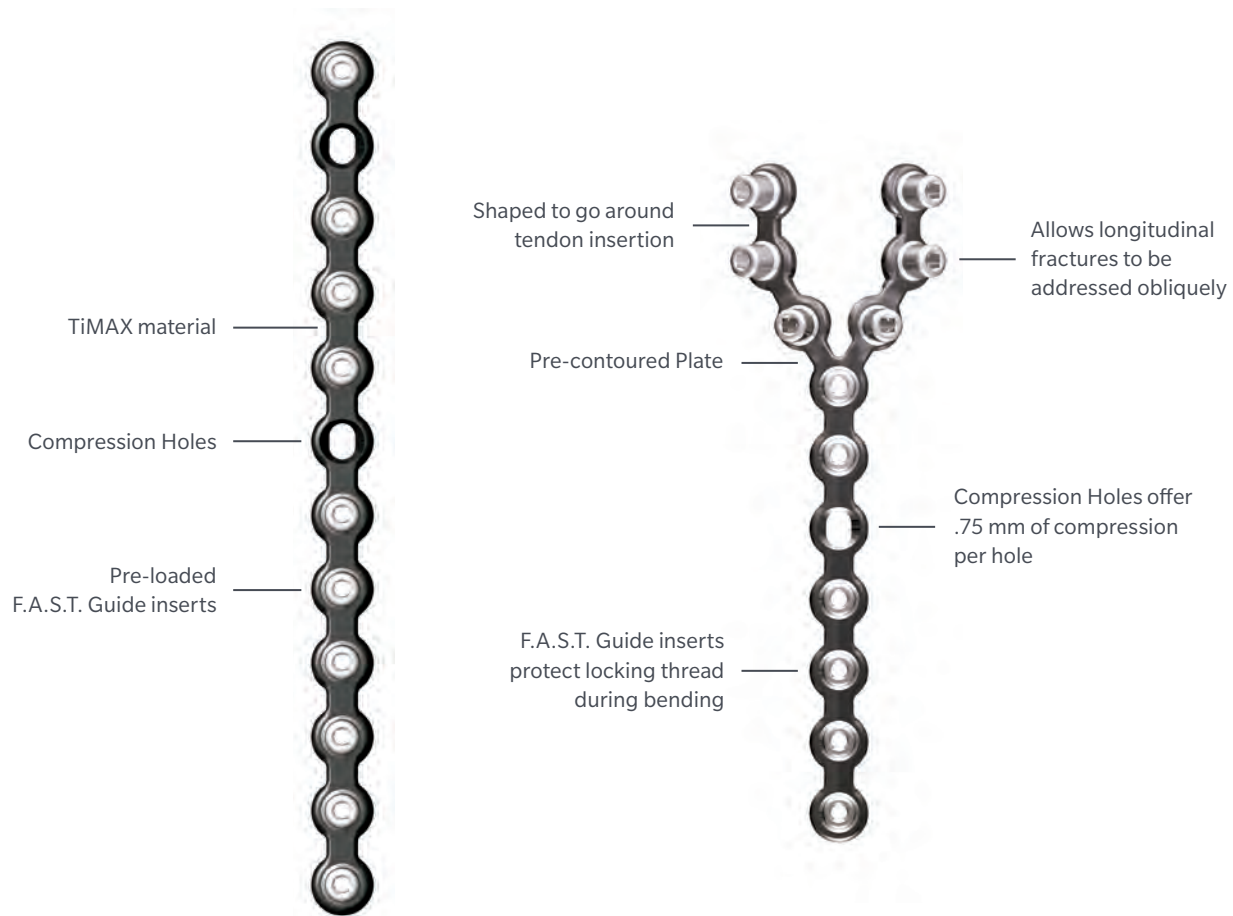

1.5 mm Plate Specifications

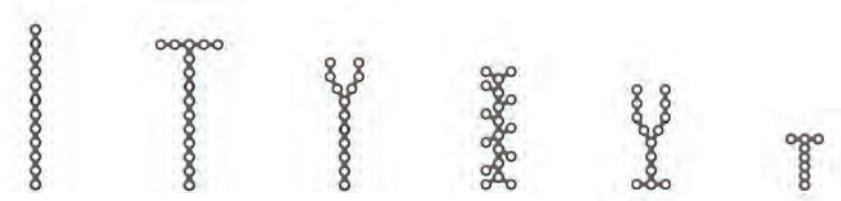

Plate Styles:	Straight	T	Y	Web	T/Y	Small T
Plate Width:	4.3 mm	20.4 mm	13.8 mm	12.8 mm	14.1 mm	13.5 mm
Plate Thickness:	1.1 mm	1.1 mm	1.1 mm	1.1 mm	1.1 mm	1.0 mm
Lengths:	61.7 mm	56.3 mm	49.6 mm	46.0 mm	39.3 mm	25.9 mm



1.5 mm Locking Cortical Screw

- CoCr screws for strength
- Self tapping tip minimizes the need for pre-tapping and eases screw insertion
- Locking screw head designed to minimize screw back-out and construct pullout
- Square drive
- Available in lengths of 8 – 24 mm
- Doubles as a multi-directional locking screw



1.5 mm Non-Locking Cortical Screw

- Self tapping tip minimizes the need for pre-tapping and eases screw insertion
- TiMAX material
- Square drive
- Available in lengths of 8 – 24 mm



1.3 mm Non-Locking Cortical Screw

- Stand alone screw
- CoCr Screw for strength
- Self tapping tip minimizes the need for pre-tapping and eases screw insertion
- Cruciate Head design
- Available in lengths of 8 – 24 mm



1.5 mm Small T Plate

- Specialty plate designed for mid-phalanx fractures
- Bridges shortened between nodes on the spine to allow more screws to be inserted in the smaller anatomy
- Arms can be contoured in all 3 planes (axial, coronal and sagittal)
- Spine can be contoured axially by skipping one node between bending irons
- Cutter must be used to shorten the spine
- Plate holder can only be used on the arms and not the spine

2.5 mm Locking Plates

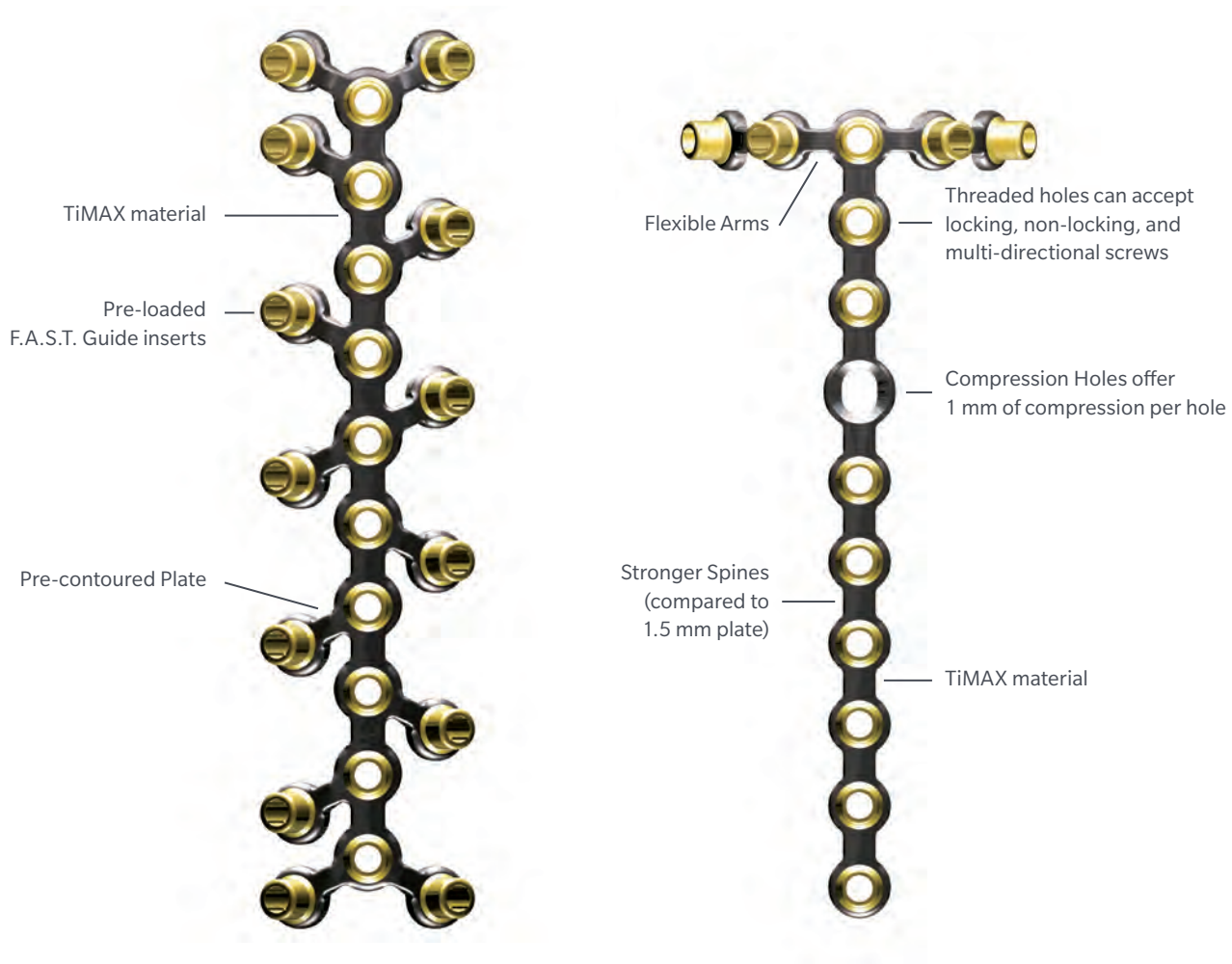

2.5 mm Plate Specifications



Plate Styles:	Straight	T	Y	Web	T/Y
Plate Width:	6.8 mm	27.6 mm	19.5 mm	17.4 mm	19.5 mm
Plate Thickness:	1.65 mm	1.65 mm	1.65 mm	1.65 mm	1.65 mm
Lengths:	90.2 mm	73.8 mm	71.8 mm	79.8 mm	55.5 mm



2.5 mm Locking Cortical Screw

- Large core diameter and shallow thread pitch for bending and shear strength
- Self tapping tip minimizes the need for pre-tapping and eases screw insertion
- Locking screw head designed to minimize screw back-out and construct pullout
- When paired with the 2.5 mm Compression Washer, it can be used as a compression screw in the 2.5 mm plate compression holes
- Square drive
- Available in lengths of 8 – 28 mm



2.5 mm Compression Washer

- Converts only the 2.5 mm Locking Cortical Screw into a compression screw
- Designed to be used in the compression holes in the 2.5 mm plates



2.5 mm Non-Locking Cortical Screw

- Self tapping tip minimizes the need for pre-tapping and eases screw insertion
- Square drive
- Available in lengths of 8 – 28 mm



2.5 mm Multi-Directional Locking Cortical Screw (MDTP)

- CoCr Screws create new thread path in the plate
- Locking screw head designed to minimize screw back-out and construct pullout
- Narrow shaft of MDTP is comparable to bending stiffness of 2.5 mm locking screws
- Square drive
- Available in lengths of 10 – 28 mm

NOTE: With enough force it is possible to drive the 2.5 mm MDTPs through the plate. Stop advancing the screw when the head of screw is flush with the surface of the plate.

Plate Options

Straight



T

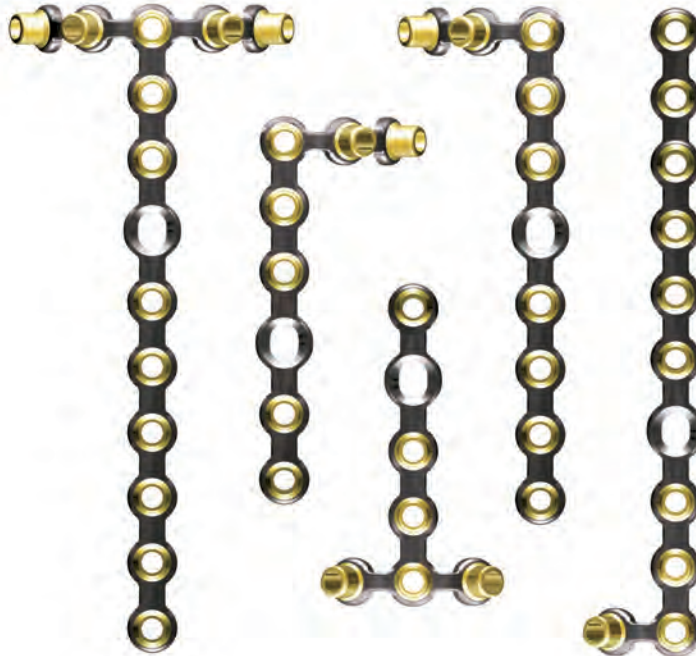

The A.L.P.S. Hand Fracture System plates were designed to be modified to meet the needs of the patient and the fracture. The plates can be shortened, cut, or shaped to create an almost infinite array of plate constructs. The plates can be shortened by using the benders or cut using the plate cutters. When shortening with the benders, it is recommended that you straddle the bridge to be removed with the benders and simply bend toward the bottom of the plate until it releases. This is the preferred shortening method since it will make the broken edge of the plate face toward the bone, keeping it hidden from the soft tissues. This simple chart demonstrates some of the plate shapes that can be created from the basic 5 shapes.

Web

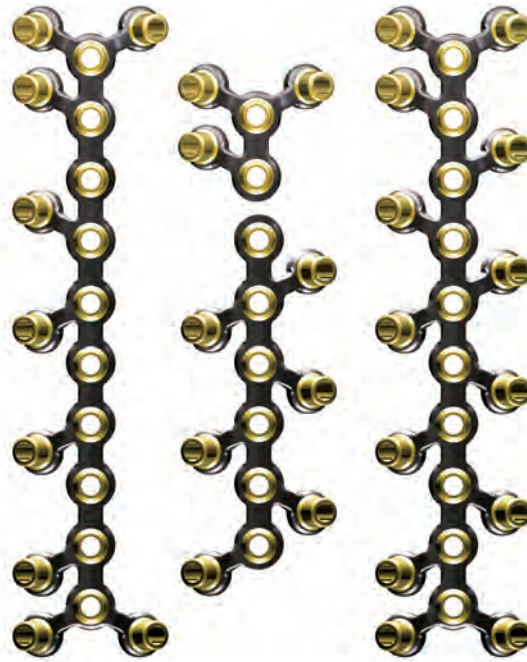

Y

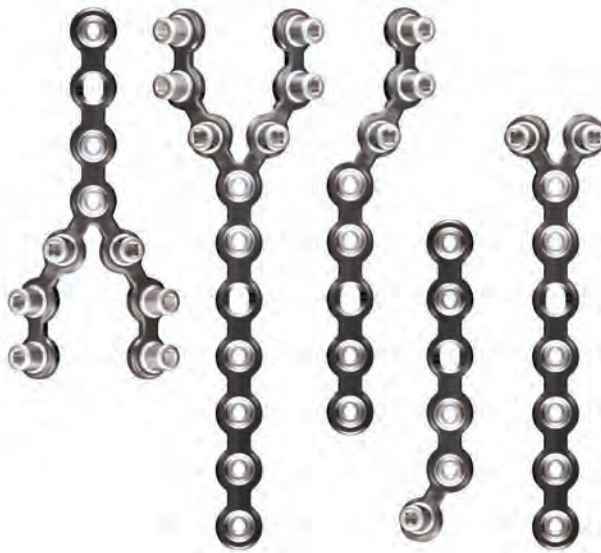

T/Y

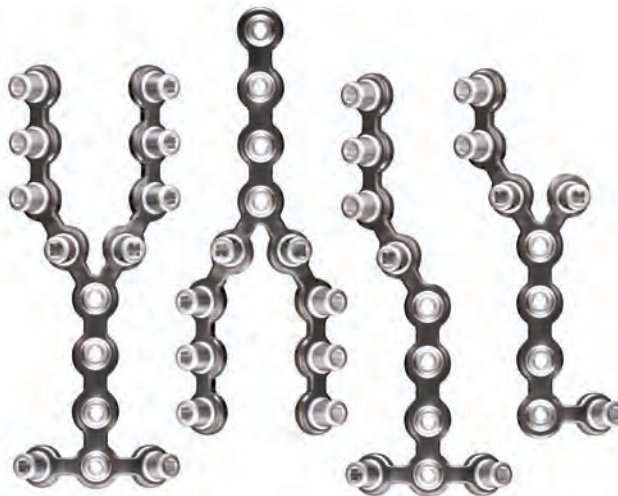

Instruments

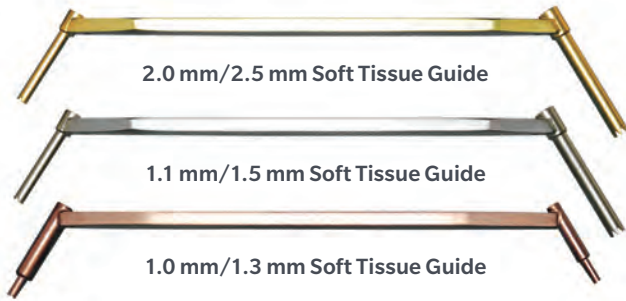

Screw Pickup
(shown with 1.3 mm Cruciate Driver)



1.5 mm Plate Holder



2.5 mm Plate Holder



1.3 mm/1.5 mm Bone Depth Gauge



2.0 mm/2.5 mm Bone Depth Gauge

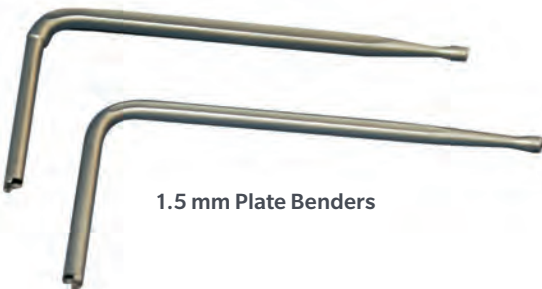

1.5 mm Plate Benders

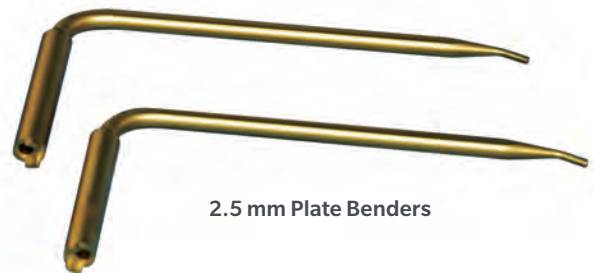

2.5 mm Plate Benders

The A.L.P.S. Hand Fracture System instrumentation provides the hand surgeon with the tools needed to perform a hand fracture procedure. To help reduce confusion when selecting the correct instrument, the modules have been color coded so that the bronze instruments are used with 1.3 mm screws, silver instruments are used with 1.5 mm plates and screws, and gold instruments are used with 2.5 mm plates and screws. Similar color coding is extended to the F.A.S.T. Guide inserts on the plates, creating a simple and convenient identification system. General instrumentation is also included in the set, allowing for a comprehensive instrumentation system that will facilitate an efficient surgical procedure.



K-wire Reduction Clamp
(use with K-wires that are .045 inches or smaller)



Small Reduction Clamps



Cutting Pliers



Elevator



Mini Quick Connect Handles (2)



Retractors (2)

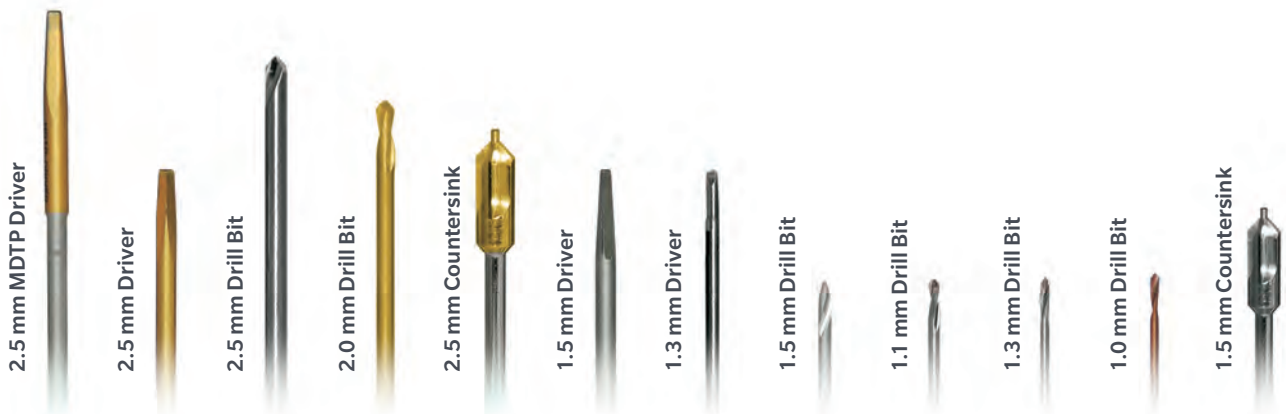

2.5 mm MDTP Driver

2.5 mm Driver

2.5 mm Drill Bit

2.0 mm Drill Bit

2.5 mm Countersink

1.5 mm Driver

1.3 mm Driver

1.5 mm Drill Bit

1.1 mm Drill Bit

1.3 mm Drill Bit

1.0 mm Drill Bit

1.5 mm Countersink

Surgical Technique

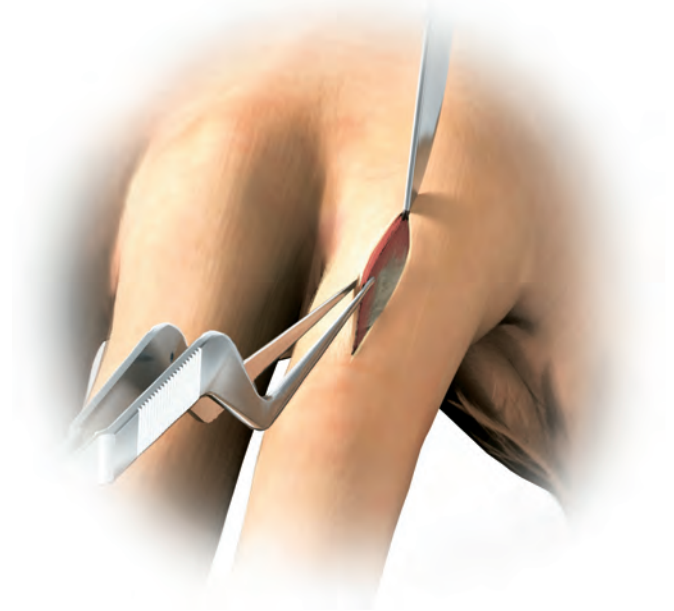

1. Assess the fracture fluoroscopically

Assess the fracture based on preoperative radiographs and/or intraoperative fluoroscopy.

- Assessment needs to consider fracture, comminution, bone loss, and geometry
- Fixation may require simply interfragmentary screw fixation, use of plate and screws, compression at the fracture site, and/or supplementation with bone graft
- In the absence of malrotation or shortening, simple plate application with locking technology provides rigidity
- In the presence of clinically relevant displacement (rotation, shortening, angulation) anatomic reduction should precede plate application or be provided via in-situ adjustment of the fracture prior to final plate fixation

2. Make an incision

- While dorsal surgical approaches to metacarpal fractures and both dorsal and lateral approaches to phalangeal fractures are feasible, the decision regarding where to make an incision and its length are subject to surgeon preference

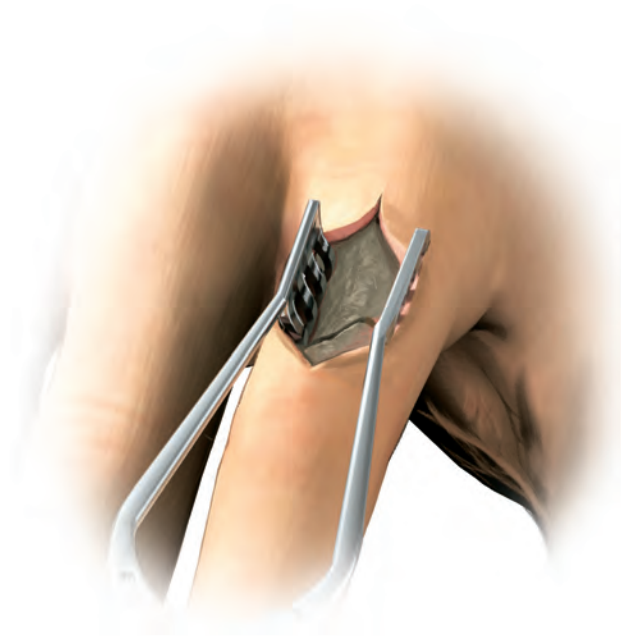

3. Reduce the fracture

- After adequate exposure and irrigation of hematoma, the fracture should be reduced
- This can usually be afforded based on visual cues, but when comminution exists, the use of intraoperative fluoroscopy may be helpful



4. Achieve temporary stabilization

Achieve provisional stabilization of the fracture and assess optimal fixation.

- This may require the use of towel clamps or other types of reduction clamps
- Provisional fixation with K-wires may also be necessary



5. Determine appropriate plate

Determine the optimal plate shape and length.

- Select the proper plate size (either 1.5 for phalangeal fractures or 2.5 for metacarpal fractures)
- Transverse diaphyseal fractures require straight plates; depending on the fracture geometry the other plate shapes can be utilized
- These can be trimmed and shortened depending on the decision regarding fixation
- Length can be assessed by placing the plate on the bone. Trimming is performed prior to fixation, but contouring can be performed in-situ

6. Prepare the plate

Prepare the plate shape, length, and contour.

- It is highly recommended that the plates be shortened by using the plate benders to create a smooth edge and avoid soft tissue and tendon irritation
 - Do this by using the benders in the F.A.S.T. Guide inserts and bending the end of the plate towards the bottom of the plate section you wish to keep
 - Alternatively, in-situ contouring can be performed after provisional plate fixation proximally and distally to the fracture
- ⊖ **Note:** For the 1.5 mm small T plate, the cutter must be used to shorten the spine due to space limitations between the nodes

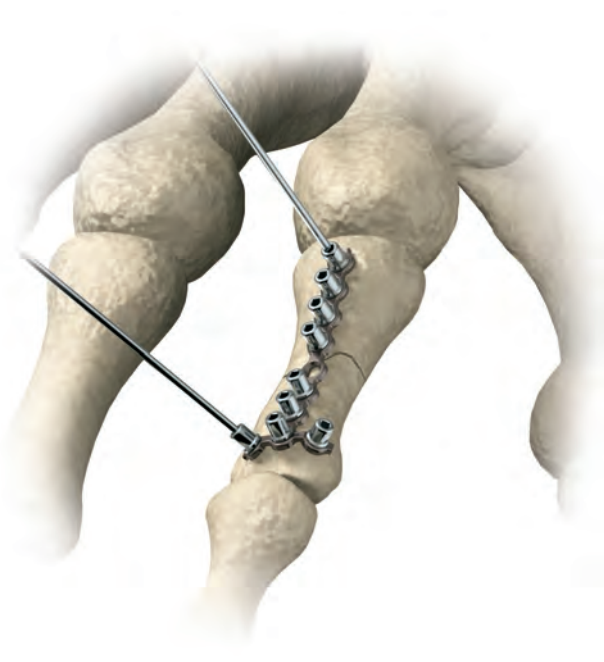

7. Achieve temporary fixation of the plate

- This may include initial placement of k-wires proximally and distally to assess plate contour (Use 0.028" and 0.035" k-wires through the 1.5 mm F.A.S.T. Guide inserts and 0.045" and 0.062" k-wires through the 2.5 mm)
- Determine whether any screws will be placed in compression node
- This may include placing the drill bit or k-wire in one F.A.S.T. Guide to assist in plate fixation while another screw is placed
- In-situ contouring, when necessary, can be provided once screw fixation proximally and distally to the fracture is afforded



8. Drill and remove F.A.S.T. Guide inserts

- After drilling with the appropriate drill (1.1 mm silver drill for a 1.5 mm screw and 2.0 mm gold drill for a 2.5 mm screw), remove the F.A.S.T. Guide inserts
- When drilling through the compression slot, use the soft tissue guide and drill on the side of the slot furthest from the fracture site
- To remove a F.A.S.T. Guide insert press the screw driver tip into the F.A.S.T. Guide insert and turn counter clockwise to disengage the guide
- The F.A.S.T. Guide inserts are disposable and must be removed



9. Insert appropriate screw

- Each locking hole provides the option for either a locked fixed angle, locked multi-directional, or non-locking screw
- The 2.5 mm MDTP is the locked multi-directional screw for the 2.5 mm plates and the 1.5 mm locked screw can be locked into the plate off axis if desired (20 degree cone)
- The 2.5 mm locking screws with the washer and the 1.5 mm non-locking screws can be used in the compression holes to provide compression to a fracture site



10. Contour plate as desired

- Plates can be bent, twisted, and curved by utilizing the plate benders
 - To bend or twist a plate in the axial or coronal plane, place the long end of the bender over (1.5 mm) or into (2.5 mm) the F.A.S.T. Guide inserts of adjacent nodes. Hold one bender as an anchor and manipulate the other
 - To curve a plate sagittally, place the short end of the benders over the F.A.S.T. Guide inserts of adjacent nodes. Hold one bender as an anchor and curve with the other
- ⓘ **Note:** The benders are a matched pair. If curving an end node use the End Node bender at that position
- ⓘ **Note:** For the 1.5 mm small T plate, the arms can be contoured in all planes, but the spine can only be contoured axially by skipping 1 node between the bending irons

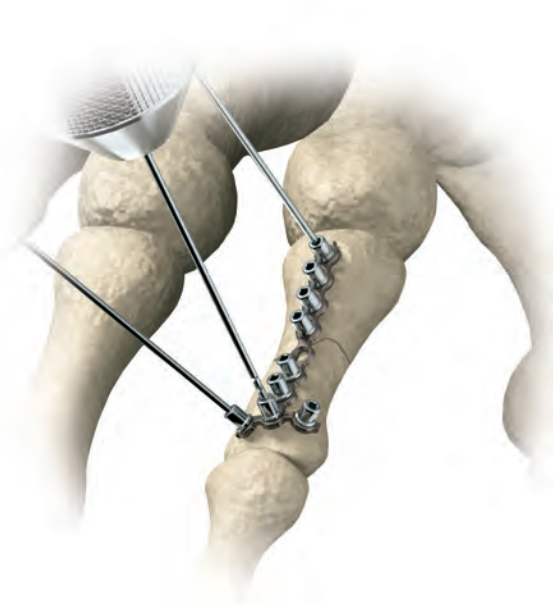

11. Achieve final fixation

- This may involve all locking screws
- Alternatively, a non-locking screw can be used to lag fragments to the plate
- When desired, 1.5 mm non-locking screws or 2.5 mm Locking (green) screws with washers can be placed through a compression hole to afford axial compression at the fracture site

12. Postoperative management

- A compressive dressing is recommended with a plaster splint or a bulky “soft” splint placed depending on the surgeon’s individual assessment of fixation and patient compliance
- Early motion of the interphalangeal and MP joints may be possible with intermittent splinting until union, depending on the surgeon’s preference and assessment of patient compliance

Multi-Directional Threaded Peg Insertion



1. Prepare and drill

- Remove the F.A.S.T. Guide inserts
- Drill through the soft tissue guide with the 2.0 mm drill (for the 2.5 mm Multi-Directional Screw) or the 1.1 mm drill (for the 1.5 mm locking screw) in the desired direction
- It is recommended that the off-axis angle is no greater than 10 degrees off center (20 degree cone). This recommendation applies to both 1.5 mm and 2.5 mm screws

2. Measure for screw length

3. Insert screws in the desired direction

- If necessary, re-drill and reinsert the screw in the desired direction

4. Lock screw into the plate

- **Note:** It is possible to drive the 2.5 mm Multi-Directional Screw through the plate. Stop inserting when the head of the screw is flush with the surface of the plate.
- When inserting the 1.5 mm screws off axis the top of the screw will stand slightly proud of the plate.

1.5 / 1.3 mm Module Components

1.5 / 1.3 mm Module Components

Product#	Description
2312-20-008	1.5 mm Stocking Module

Non-Locking Screw 1.3 mm

Product#	Description
1312-20-308	Non Locking Screw 1.3 mm x 8 mm
1312-20-309	Non Locking Screw 1.3 mm x 9 mm
1312-20-310	Non Locking Screw 1.3 mm x 10 mm
1312-20-311	Non Locking Screw 1.3 mm x 11 mm
1312-20-312	Non Locking Screw 1.3 mm x 12 mm
1312-20-313	Non Locking Screw 1.3 mm x 13 mm
1312-20-314	Non Locking Screw 1.3 mm x 14 mm
1312-20-315	Non Locking Screw 1.3 mm x 15 mm
1312-20-316	Non Locking Screw 1.3 mm x 16 mm
1312-20-318	Non Locking Screw 1.3 mm x 18 mm
1312-20-320	Non Locking Screw 1.3 mm x 20 mm
1312-20-322	Non Locking Screw 1.3 mm x 22 mm
1312-20-324	Non Locking Screw 1.3 mm x 24 mm

Non-Locking Screw 1.3 mm (Sterile)

Product#	Description
1512-20-308	1.3 x 8 mm Non Lock Screw STE
1512-20-309	1.3 x 9 mm Non Lock Screw STE
1512-20-310	1.3 x 10 mm Non Lock Screw STE
1512-20-311	1.3 x 11 mm Non Lock Screw STE
1512-20-312	1.3 x 12 mm Non Lock Screw STE
1512-20-313	1.3 x 13 mm Non Lock Screw STE
1512-20-314	1.3 x 14 mm Non Lock Screw STE
1512-20-315	1.3 x 15 mm Non Lock Screw STE
1512-20-316	1.3 x 16 mm Non Lock Screw STE

1.5 mm Locking Plates

Product#	Description
1312-20-151	1.5 mm Locking plate, Straight
1312-20-152	1.5 mm Locking plate, T-Shape
1312-20-153	1.5 mm Locking plate, Y-Shape
1312-20-154	1.5 mm Locking plate, T/Y Shape
1312-20-155	1.5 mm Locking plate, Web
1312-20-157	1.5 mm Locking plate, Small T-Shape

1.5 mm Locking Plates (Sterile)

Product#	Description
1512-21-151	1.5 mm Locking plate, Straight
1512-21-152	1.5 mm Locking plate, T-Shape
1512-21-153	1.5 mm Locking plate, Y-Shape
1512-21-154	1.5 mm Locking plate, T/Y Shape
1512-21-155	1.5 mm Locking plate, Web
1512-21-157	1.5 mm Locking plate, Small T-Shape

Non Locking Screw 1.5 mm

Product#	Description
1312-20-508	Non Locking Screw 1.5 mm x 8 mm
1312-20-509	Non Locking Screw 1.5 mm x 9 mm
1312-20-510	Non Locking Screw 1.5 mm x 10 mm
1312-20-511	Non Locking Screw 1.5 mm x 11 mm
1312-20-512	Non Locking Screw 1.5 mm x 12 mm
1312-20-513	Non Locking Screw 1.5 mm x 13 mm
1312-20-514	Non Locking Screw 1.5 mm x 14 mm
1312-20-515	Non Locking Screw 1.5 mm x 15 mm
1312-20-516	Non Locking Screw 1.5 mm x 16 mm
1312-20-518	Non Locking Screw 1.5 mm x 18 mm
1312-20-520	Non Locking Screw 1.5 mm x 20mm
1312-20-522	Non Locking Screw 1.5 mm x 22 mm
1312-20-524	Non Locking Screw 1.5 mm x 24 mm

Non Locking Screw 1.5 mm (Sterile)

Product#	Description
1512-20-508	1.5 x 8 mm Non Lock Screw STE
1512-20-509	1.5 x 9 mm Non Lock Screw STE
1512-20-510	1.5 x 10 mm Non Lock Screw STE
1512-20-511	1.5 x 11 mm Non Lock Screw STE
1512-20-512	1.5 x 12 mm Non Lock Screw STE
1512-20-513	1.5 x 13 mm Non Lock Screw STE
1512-20-514	1.5 x 14 mm Non Lock Screw STE
1512-20-515	1.5 x 15 mm Non Lock Screw STE
1512-20-516	1.5 x 16 mm Non Lock Screw STE
1512-20-518	1.5 x 18 mm Non Lock Screw STE
1512-20-520	1.5 x 20 mm Non Lock Screw STE

Locking Screw 1.5 mm

Product#	Description
1312-20-408	1.5 x 8 mm Locking Screw
1312-20-409	1.5 x 9 mm Locking Screw
1312-20-410	1.5 x 10 mm Locking Screw
1312-20-411	1.5 x 11 mm Locking Screw
1312-20-412	1.5 x 12 mm Locking Screw
1312-20-413	1.5 x 13 mm Locking Screw
1312-20-414	1.5 x 14 mm Locking Screw
1312-20-415	1.5 x 15 mm Locking Screw
1312-20-416	1.5 x 16 mm Locking Screw
1312-20-418	1.5 x 18 mm Locking Screw
1312-20-420	1.5 x 20 mm Locking Screw
1312-20-422	1.5 x 22 mm Locking Screw
1312-20-424	1.5 x 24 mm Locking Screw

Locking Screw 1.5 mm (Sterile)

Product#	Description
1512-20-408	1.5 x 8 mm Locking Screw STE
1512-20-409	1.5 x 9 mm Locking Screw STE
1512-20-410	1.5 x 10 mm Locking Screw STE
1512-20-411	1.5 x 11 mm Locking Screw STE
1512-20-412	1.5 x 12 mm Locking Screw STE
1512-20-413	1.5 x 13 mm Locking Screw STE
1512-20-414	1.5 x 14 mm Locking Screw STE
1512-20-415	1.5 x 15 mm Locking Screw STE
1512-20-416	1.5 x 16 mm Locking Screw STE
1512-20-418	1.5 x 18 mm Locking Screw STE
1512-20-420	1.5 x 20 mm Locking Screw STE

2.5 mm Module Components

2.5 mm Module Components

Product#	Description
2312-20-007	2.5 mm Stocking Module

2.5 mm Locking Plates

Product#	Description
1312-20-251	2.5 mm Locking plate, Straight
1312-20-252	2.5 mm Locking plate, T-Shape
1312-20-253	2.5 mm Locking plate, Y-Shape
1312-20-254	2.5 mm Locking plate, T/Y Shape
1312-20-255	2.5 mm Locking plate, Web

2.5 mm Locking Plates (Sterile)

Product#	Description
1512-20-251	2.5 mm Straight Plate STE
1512-20-252	2.5 mm T Locking Plate STE
1512-20-253	2.5 mm Y Locking Plate STE
1512-20-254	2.5 mm T/Y Locking Plate STE
1512-20-255	2.5 mm WEB Locking Plate STE

Screw Peg 2.5 mm

Product#	Description
SP08000	Screw Peg 2.5 mm x 8 mm
SP09000	Screw Peg 2.5 mm x 9 mm
SP10000	Screw Peg 2.5 mm x 10 mm
SP11000	Screw Peg 2.5 mm x 11 mm
SP12000	Screw Peg 2.5 mm x 12 mm
SP13000	Screw Peg 2.5 mm x 13 mm
SP14000	Screw Peg 2.5 mm x 14 mm
SP15000	Screw Peg 2.5 mm x 15 mm
SP16000	Screw Peg 2.5 mm x 16 mm
SP18000	Screw Peg 2.5 mm x 18 mm
SP20000	Screw Peg 2.5 mm x 20 mm
SP22000	Screw Peg 2.5 mm x 22 mm
SP24000	Screw Peg 2.5 mm x 24 mm
SP26000	Screw Peg 2.5 mm x 26 mm
SP28000	Screw Peg 2.5 mm x 28 mm

Screw Peg 2.5 mm (Sterile)

Product#	Description
1312-12-508	Screw Peg 2.5 mm x 08 mm
1312-12-509	Screw Peg 2.5 mm x 09 mm
1312-12-510	Screw Peg 2.5 mm x 10 mm
1312-12-511	Screw Peg 2.5 mm x 11 mm
1312-12-512	Screw Peg 2.5 mm x 10 mm
1312-12-513	Screw Peg 2.5 mm x 13 mm
1312-12-514	Screw Peg 2.5 mm x 14 mm
1312-12-516	Screw Peg 2.5 mm x 16 mm
1312-12-518	Screw Peg 2.5 mm x 18 mm
1312-12-520	Screw Peg 2.5 mm x 20 mm
1312-12-522	Screw Peg 2.5 mm x 22 mm
1312-12-524	Screw Peg 2.5 mm x 24 mm
1312-12-526	Screw Peg 2.5 mm x 26 mm
1312-12-528	Screw Peg 2.5 mm x 28 mm

Fully Threaded Peg 2.5 mm

Product#	Description
FP08	Fully Threaded Peg 2.5 mm x 8 mm
FP09	Fully Threaded Peg 2.5 mm x 9 mm
FP10	Fully Threaded Peg 2.5 mm x 10 mm
FP11	Fully Threaded Peg 2.5 mm x 11 mm
FP12	Fully Threaded Peg 2.5 mm x 12 mm
FP13	Fully Threaded Peg 2.5 mm x 13 mm
FP14	Fully Threaded Peg 2.5 mm x 14 mm
FP15	Fully Threaded Peg 2.5 mm x 15 mm
FP16	Fully Threaded Peg 2.5 mm x 16 mm
FP18	Fully Threaded Peg 2.5 mm x 18 mm
FP20	Fully Threaded Peg 2.5 mm x 20 mm
FP22	Fully Threaded Peg 2.5 mm x 22 mm
FP24	Fully Threaded Peg 2.5 mm x 24 mm
FP26	Fully Threaded Peg 2.5 mm x 26 mm
FP28	Fully Threaded Peg 2.5 mm x 28 mm

Fully Threaded Peg 2.5 mm (Sterile)

Product#	Description
1312-12-610	Fully Threaded Peg 2.5 mm x 10
1312-12-612	Fully Threaded Peg 2.5 mm x 12
1312-12-614	Fully Threaded Peg 2.5 mm x 14
1312-12-616	Fully Threaded Peg 2.5 mm x 16
1312-12-618	Fully Threaded Peg 2.5 mm x 18
1312-12-620	Fully Threaded Peg 2.5 mm x 20
1312-12-622	Fully Threaded Peg 2.5 mm x 22
1312-12-624	Fully Threaded Peg 2.5 mm x 24
1312-12-626	Fully Threaded Peg 2.5 mm x 26
1312-12-628	Fully Threaded Peg 2.5 mm x 28

2.5 mm Threaded Washer

Product#	Description
1312-20-025	2.5 mm Threaded Washer

2.5 mm Threaded Washer (Sterile)

Product#	Description
1512-20-025	2.5 mm Threaded Washer

2.5 mm Multi-Directional Threaded Peg Screws

Product#	Description
1312-11-108	Multi-Directional Threaded Peg 2.5 mm x 8 mm
1312-11-109	Multi-Directional Threaded Peg 2.5 mm x 9 mm
1312-11-110	Multi-Directional Threaded Peg 2.5 mm x 10 mm
1312-11-111	Multi-Directional Threaded Peg 2.5 mm x 11 mm
1312-11-112	Multi-Directional Threaded Peg 2.5 mm x 12 mm
1312-11-113	Multi-Directional Threaded Peg 2.5 mm x 13 mm
1312-11-114	Multi-Directional Threaded Peg 2.5 mm x 14 mm
1312-11-115	Multi-Directional Threaded Peg 2.5 mm x 15 mm
1312-11-116	Multi-Directional Threaded Peg 2.5 mm x 16 mm
1312-11-118	Multi-Directional Threaded Peg 2.5 mm x 18 mm
1312-11-120	Multi-Directional Threaded Peg 2.5 mm x 20 mm
1312-11-122	Multi-Directional Threaded Peg 2.5 mm x 22 mm
1312-11-124	Multi-Directional Threaded Peg 2.5 mm x 24 mm
1312-11-126	Multi-Directional Threaded Peg 2.5 mm x 26 mm
1312-11-128	Multi-Directional Threaded Peg 2.5 mm x 28 mm
1312-11-130	Multi-Directional Threaded Peg 2.5 mm x 30 mm

2.5 mm Module Components (cont.)

2.5 mm Multi-Directional Threaded Peg Screws (Sterile)

Product#	Description
1312-12-410	Multi-Directional Threaded Peg 2.5 mm x 10 mm
1312-12-411	Multi-Directional Threaded Peg 2.5 mm x 11 mm
1312-12-412	Multi-Directional Threaded Peg 2.5 mm x 12 mm
1312-12-413	Multi-Directional Threaded Peg 2.5 mm x 13 mm
1312-12-414	Multi-Directional Threaded Peg 2.5 mm x 14 mm
1312-12-415	Multi-Directional Threaded Peg 2.5 mm x 15 mm
1312-12-416	Multi-Directional Threaded Peg 2.5 mm x 16 mm
1312-12-418	Multi-Directional Threaded Peg 2.5 mm x 18 mm
1312-12-420	Multi-Directional Threaded Peg 2.5 mm x 20 mm
1312-12-422	Multi-Directional Threaded Peg 2.5 mm x 22 mm
1312-12-424	Multi-Directional Threaded Peg 2.5 mm x 24 mm
1312-12-426	Multi-Directional Threaded Peg 2.5 mm x 26 mm
1312-12-428	Multi-Directional Threaded Peg 2.5 mm x 28 mm

Disposables

Disposables – Single Use Devices

Product#	Description
2312-11-002	MDTP Driver Bit
2312-20-200	1.0 mm Drill Bit w/ Mini-Quick Connect
2312-20-201	1.3 mm Drill Bit w/ Mini-Quick Connect
2312-20-202	FAST 1.1 mm Drill Bit w/ Mini-Quick Connect
2312-20-203	1.5 mm Drill Bit w/ Mini-Quick Connect
2312-20-204	FAST 2.0 mm Drill Bit w/ Mini-Quick Connect
2312-20-205	2.5 mm Drill Bit w/ Mini-Quick Connect
2312-20-206	1.3 mm / 1.5mm Countersink
2312-20-207	2.0 mm / 2.5mm Countersink
2312-20-208	1.3 mm Driver Bit
2312-20-209	1.5 mm Driver Bit
2312-20-211	2.0 mm / 2.5 mm Driver Bit
1642-06-028	K-Wire 6" Trocar Point .028 OD
1642-06-035	K-Wire 6" Trocar Point .035 OD
1642-06-045	K-Wire 6" Trocar Point .045 OD
1642-06-062	K-Wire 6" Trocar Point .062 OD

Disposables – Single Use Devices (Sterile)

Product#	Description
2312-21-200	1.0 x 56 mm Drill Mini Quick Connect STE
2312-21-201	1.3 mm Drill Bit Mini Quick Connect
2312-21-202	1.1 x 56 mm Drill Fast Mini Quick Connect STE
2312-21-203	1.5 x 56 mm Drill Mini Quick Connect STE

INDICATIONS

For stabilization and fixation of small bone fragments in fresh fractures, revision procedures, joint fusion and reconstructions of small bones of the hand, foot, wrist, ankle, humerus, scapula, finger, toe, pelvis and craniomaxillofacial skeleton, particularly in osteopenic bone.

CONTRAINDICATIONS

(orthopaedic screws, intramedullary nails, plates, compression hip screws, pins and wires):

- Cases where there is an active infection.
- Conditions which tend to retard healing such as, blood supply limitations, previous infections, etc.
- Insufficient quantity or quality of bone to permit stabilization of the fracture complex and/or fusion of the joints.
- Conditions that restrict the patient's ability or willingness to follow postoperative instructions during the healing process.
- Foreign body sensitivity – where material sensitivity is suspected, appropriate tests should be made and sensitivity ruled out prior to implantations.
- Cases where the implant(s) would cross open epiphyseal plates in skeletally immature patients.

ADDITIONAL CONTRAINDICATIONS – Orthopaedic Screws and Plates Only:

- Cases with malignant primary or metastatic tumors which preclude adequate bone support or screw fixations, unless supplemental fixation or stabilization methods are utilized.

This publication and all content, is protected by copyright, trademarks and other intellectual property rights owned by or licensed to Zimmer Biomet or its affiliates unless otherwise indicated.

This material is intended for the physicians and the Zimmer Biomet sales force only. The distribution to any other recipient is prohibited.

This publication must not be used, copied or reproduced in whole or in part without the express written consent of Zimmer Biomet or its authorised representatives.

For complete product information see the package insert and www.zimmerbiomet.com (where available). Check for country product clearances and reference product specific instructions for use.

This technique and postoperative management protocol is utilized by the designing surgeons. Zimmer Biomet does not practice medicine. The surgeon who performs any implant procedure is responsible for determining and utilizing the appropriate treatment, technique(s), and products for each individual patient.

©2015 Zimmer Biomet



Authorized Representative

Biomet UK Limited
Waterton Industrial Estate
Bridgend, South Wales
CF31 3XA
United Kingdom



ZIMMER BIOMET

Your progress. Our promise.™



Legal Manufacturer

Biomet Trauma
P.O. Box 587
56 East Bell Drive
Warsaw, Indiana 46581-0587
USA

www.biomet.com

CE0086

CE mark on a surgical technique is not valid unless there is a CE mark on the product label.

0008.2-GLBL-en-REV1015